

**City of Meriden Proposal to Implement the  
Multi-Modal Roadway Improvement Plan in the TOD District  
February 4, 2016**

**Summary**

The City of Meriden, CT is seeking \$2 million from the State of Connecticut to improve six (6) roadway sections in downtown Meriden, including Colony Street, West Main Street, State Street, Perkins Square/South Colony Street and East Main Street, to improve traffic flow, improve accessibility and increase safety for vehicles, bicyclists and pedestrians traveling within Meriden's TOD zoning district. The roadway sections were selected and analyzed for improvements in prior studies and investigations including the TOD Master Plan (completed in 2012 with the assistance of Parsons Brinkerhoff, Luchs Engineering, and Form + Place architects), the 35% Engineering Design Plans completed by CDM Smith in 2015, and the 100% design plans for West Main Street and Colony Street completed in 2016. The project is an outgrowth of two State of Connecticut TOD Pilot grants, a US Dept. of Housing and Urban Development (HUD) Sustainable Challenge grant and a HUD Choice Neighborhoods Planning grant.

Prior planning efforts show that the local roadway, sidewalk and bicycle network is insufficient to meet current and future needs. Increasing mobility and connectivity, as well as converting vehicles to other modes of transportation, are viewed as critical to the future success of Meriden and the viability of it as a transit oriented community. The proposed project will help ensure that pedestrians, bicyclists, vehicles, transit buses and the disabled are afforded safe and efficient access to the new Meriden Transit Center (MTC), commuter rail service, over 500 new housing units and over 100,000 square feet of commercial/flex space to be constructed over the next five years. State funds will be matched with \$1 million in local funds and will leverage \$100 million in ongoing investments in flood control, housing and transportation projects. The project is a part of a regional commuter rail project that will have a significant impact on the New Haven/Hartford area.

**(1) Description of existing conditions in the proposed project area (i.e., transportation facilities, parking, employment, residential, commercial/retail, brownfields, building vacancy rate, parking spaces, zoning regulations, etc.). If available, include maps as supplemental attachments**

The City of Meriden, population 60,838, is centrally located in Connecticut at the intersections of Interstates I-91, I-691 and the Merritt Parkway (Route 15), midway between Hartford and New Haven and less than two hours from Boston and New York City. Meriden is home to 1,300 businesses employing over 25,000 people, 3,000 acres of park space, and a distinguished history. Meriden, once known as the "Silver City", enjoyed economic prosperity through the 1950's due to a thriving silver manufacturing industry. A decline in silver industries, related plant closings, and unsuccessful urban renewal policies resulted in significant disinvestment in Meriden's city center in the 1960's. Several downtown "revitalization" projects, which ranged from the construction of streetscape improvements to the development of an indoor mall, were undertaken from the 1970s through the 1990s. Those efforts, however, did not have the desired effect of spurring economic activity downtown. Two major floods in 1992 and 1996, which caused over \$26 million in property damage, halted new development activities from the late 1990s to the present.

Over the past several years, the City has positioned its downtown for significant change. The City's goal is to transform its city center into a modern, urban area that offers new, mixed-use development in a pedestrian-friendly environment with public open space and access to public transit service. The City has worked in close collaboration with state and federal agencies, educational

institutions, non-profit organizations, foundations, and private sector partners to resolve historic flooding issues, clean up over 36 acres of underutilized brownfield sites, remake the current rail station area and redevelop the obsolete and the distressed public housing complex at the core of the city center. More than \$100 million in federal, State and City funding is, or will be, invested in these efforts in the next several years.

Meriden's transformation began in earnest in 2015 with the groundbreaking of several important projects including the Hub park and flood control project, reconstruction of the Meriden Transit Center, and the 24 Colony Street mixed use development project. The Hub project is a \$14 million City park and flood storage area that is part of a \$50 million citywide flood control infrastructure upgrade and the City's Linear Trail system. Implementation of the flood control program will significantly reduce flooding risks for existing and new development downtown and create an attractive public park, linear greenway trail and central town green around which development can be constructed.

The Hub is located across the street from the Meriden Transit Center, which also began a major transformation last year. In 2015, the Connecticut Department of Transportation began construction of a \$20 million rail station to replace Meriden's aging Amtrak station. The investment is part of the Hartford Line rail program, a \$500 million commuter/high speed rail service utilizing the existing Amtrak rail corridor between Springfield and New Haven. Meriden has been designated a key station stop along the rail line. At full capacity, Meriden will have 56 bi-directional trains daily serving the Springfield to New Haven corridor and improved transit bus service. New commuter rail service positions Meriden as a potential housing choice for persons who want to commute to one of the many employment centers (with nearly 140,000 jobs) along the transit line (e.g., Hartford, New Haven and parts of Fairfield County).

Finally, in 2015, construction commenced on the \$24 million mixed use development at 24-38-44 Colony Street in downtown Meriden. This development is the City's first "Transit Oriented Development" and the first significant new private development in downtown Meriden in over 40 years. The project is scheduled to be completed in late 2016 and will offer 63 rental housing units and 11,000 square feet of retail space in the heart of the TOD district. The developer Westmount is also constructing an \$8 million, 273-space commuter parking garage for ConnDOT co-located with the mixed use development. In 2017, ConnDOT will also be constructing a surface lot on State Street with 80 parking spaces for daily commuters. This is in addition to 769 on-street, surface lot, and garage parking spaces currently available downtown.

In addition to these ongoing construction projects, the City made significant progress on advancing private, mixed use, Transit Oriented Development on several City-owned sites in downtown Meriden. These development plans include over 500 housing units, 100,000 square feet of non-residential space and \$125 million in private investment within the next five years. The City selected Pennrose Properties LLC to develop 3 acres at the Hub site (1-77 State Street), selected POKO Partners LLC to develop 10 acres and rehabilitate a 70,000 sf former mill building at 116 Cook Avenue/Factory H (104 Butler Street/77 Cooper Street), and selected the Michaels Organization to redevelop 11 Crown Street following the demolition of the 33,000 sf former newspaper headquarters. Pennrose Properties is also working with the Meriden Housing Authority to develop a \$24 million, 75-unit mixed use development that includes 7500 square feet of non-residential space at 161 & 177 State Street. Pennrose Properties LLC applied for 9% Low Income Housing Tax Credits to fund the project in 2015 and that application is pending.

In 2013, the City adopted a Transit Oriented Development District Zoning Regulation to ensure that new development is of high quality and blends with the existing historic character. The zoning regulation is supported by the City's 2009 Plan of Conservation and Development (POCD).

**(2) Identification of the immediate need for the proposed project, and how it advances the municipality's long-term vision for the proposed project area;**

This application, if funded, will allow the City to construct specific TOD Multimodal Improvement projects that are directly tied to pending development projects that will be completed in the next 18-24 months. All of the proposed improvements have been 35% designed and several sections have final design plans completed. The implementation of the selected roadway improvements are a key component of the City's efforts to modernize its downtown roadway system and provide safe access to the Meriden Transit Center and mixed use development projects as they are constructed.

Prior planning efforts completed by the City of Meriden show that Meriden's existing downtown roadway system is confusing for vehicle modes and confusing and often dangerous for non-vehicle modes including pedestrians, bicyclists and the disabled. Access to the public transit system is hindered due to the fact that sidewalks and crosswalks are in disrepair, bus stops are not sheltered, wayfinding signs are haphazard, and bicycle lanes are non-existent. In a recent survey of downtown residents as part of the HUD Choice Neighborhood planning process, over 18% of survey respondents use public transit as their primary means of transportation and over 18% primarily walk or bike. Only 60% use or share a personal automobile and 32% percent said they cannot afford a personal automobile. Over 80% of survey respondents expressed a willingness to commute to work and/or obtain employment. However, pedestrian safety (such as interaction with speeding vehicles) was a key concern and a barrier to expanded use of the public transit system by downtown residents.

Further compounding the confusing and often dangerous traffic patterns is that previous improvements did not account for long-term maintenance needs. In 1991, a downtown streetscape project was implemented that included brickwork and sidewalk bump outs. While some of the elements remain in fair condition, bump out configuration on West Main Street and Colony Street has made plowing and street sweeping time consuming and expensive. Brick pavers used in the sidewalks were thin set and have a tendency to pop out. Trees have outgrown the tree wells, cracking the sidewalks and lifting the grates. Bump outs reduce the availability of on-street parking and vehicles in the act of parking cause all traffic to stop while they attempt to maneuver into the spaces. Vehicle speeds are high due to the lack of opposing traffic or pedestrian activity. There is frequent weaving as vehicles position for lanes and avoidance of the aforementioned parking vehicles. Overall, the existing streetscapes are difficult to maintain properly and the overall appearance decreases quality of life throughout downtown Meriden. It is the City's goal to have the roadway and sidewalk improvements completed as the new developments come online.

In 2015, the Multimodal Roadway Improvement Plan for the TOD District (Plan) was finalized. The plan, which includes 35% Preliminary Engineering Designs for the entire TOD district, was developed to outline strategies and engineering designs that address the existing deficiencies of the downtown transportation system while ensuring that pedestrians, bicyclists, vehicles and transit buses are afforded safe and efficient access to the new Meriden Transit Center, commuter rail service, new housing, economic and employment opportunities. Funds for this project were provided by a 2011 ConnDOT TOD Pilot grant and city funds. This application will address these deficiencies by constructing specific TOD Multimodal Improvement projects that are directly tied to pending development. The specific roadway sections to be improved and the related development projects that will benefit are described below.

### **a. West Main Street & Colony Street**

Project Status: Final design plans available for bumpout and signal removal; sidewalk reconstruction to be built to city standards. Sidewalk reconstruction from Grove St. to Cook Ave. completed in 2015.

Total Cost: \$621,000-West Main Street  
\$512,900-Colony Street  
\$1,133,900 total

Related Development Projects: 24 Colony Street (Westmount/MHA), Meriden Transit Center

In 2015, the City received a grant from OPM in the amount of \$125,000 to finalize the design plans for the two most critical corridors in downtown Meriden: West Main Street and Colony Street. West Main and Colony Streets are at the core of the City's central business district and Transit Oriented Development (TOD) district and form the spine of the West Main/Colony Street National Historic District (registered in 1987). Since the grant funds were awarded, the City completed 80 percent final design, engineering plans and bid specifications for West Main Street and Colony Street reconstruction and complete streets implementation including sidewalk reconstruction, bumpout removal, and signal removal at Barrister's Court. Sidewalk reconstruction from Grove Street to Cook Avenue (south side only) was completed in 2015. The City has approved local Capital Improvement Bond funds to complete sidewalk reconstruction on West Main Street from Colony Street to Grove Street and on Colony Street to Church Street. The City is seeking state funds to reconstruct sidewalks on Colony Street from Church Street to Cross Street. This work is designed to improve pedestrian and bicycle access to the 63-unit, 11,000 square foot mixed income, mixed use "transit oriented development" at 24-38-44 Colony Street and to the new Meriden Transit Center via a new pedestrian walkway to be installed by ConnDOT at 25 Colony Street. The target date for completion of both the sidewalk and street improvements and the development project is November 2016. The City has approved \$1,000,000 in City Capital Improvement Bond funds for this project.

### **b. State Street and the Hub site**

Project Status: Sidewalk reconstruction to be built to city standards

Total Cost: \$735,489

Related Development Projects: Meriden Hub park and mixed use development (Pennrose)

The City is in the process of completing the Hub Park and flood control project, a \$14 million park and flood storage area that is part of a \$50 million citywide flood control infrastructure upgrade and the City's Linear Trail system. The Hub Park will serve the dual purpose of providing flood water storage following major storm events and public open space. The Hub Park includes several public amenities, including concrete walkways, public gathering spaces, a 500-seat amphitheater and stage, and a pedestrian bridge connecting Pratt Street to the entrance to the new transit center located on State Street. The Hub site also has three (3) acres set aside for development. The City is seeking state funds to reconstruct sidewalks that are in disrepair on State Street, Pratt Street and East Main Street bordering the Hub site. State funds would also be used to repave State Street. This work is designed to improve access to the Hub and Meriden Transit Center for pedestrians, bicycles and the disabled and also to improve access to the future Pennrose developments at the Hub site, which includes 170 housing units and 85,000 square feet of commercial/retail space, and at 161-177 State Street, which includes 75 housing units and 7500 square feet of retail space. The target date for completion of both the sidewalk and street improvements is November 2016.

### **c. Cook Avenue (State Route 71) Two-Way Conversion**

Project Status: 35% engineering design plans completed

Total Cost: \$750,000

Related Development Projects: 116 Cook Ave./Factory H mixed use development (POKO Partners)

The TOD Multi Modal Improvement Plan recommends the conversion of Cook Avenue from Hanover Street to West Main Street from one way to two way. The City is seeking state funds to complete final engineering design plans, replace two traffic signals, remove two traffic islands, and install new signage. This work is designed to improve access to the future POKO development at 116 Cook Ave. and Factory H, which includes historic preservation and adaptive reuse of 116 Cook Ave., a 70,000 former mill building, and the phased development of 184 new rental housing units over six years. The roadway improvement project is also intended to improve access to the former Meriden Wallingford hospital site, a 300,000 sf building and brownfield site currently undergoing site assessment and remediation. This project will also allow traffic on state Route 71 to remain on the state road rather than being diverted to the local road system.

**d.Perkins Square/South Colony Street and Crown Street**

Project Status: Contract documents to remove wall pending. Sidewalk reconstruction to be built to city standards

Total Cost: \$274,500

Related Development Projects: 11 Crown Street mixed use development (Michaels Organization)

The TOD Multi Modal Improvement Plan recommends the realignment of Perkins Square, comprised of South Colony Street, Perkins Street and Crown Street) to improve safety and convert from one-way to two-way traffic. The plan also recommends sidewalk widening and adding crosswalks to improve pedestrian mobility. The City is seeking state funds to complete a component of the plan in order to enhance the proposed mixed use development at 11 Crown Street. The project will remove the former Church and Morse and Liseo building slabs located at 33-51 South Colony Street (City owned, demolished in 2014 for flood control purposes) and replace the area with open space, landscaping and public sidewalks. This work is designed to improve access to and from the future Michaels Organization development at 11 Crown Street, an 81 unit mixed use development to replace the former 30,000 sf Record Journal building, that will be demolished and remediated by the City under a previously awarded DECD municipal brownfields cleanup grant.

**e.East Main Street Transit Stop**

Project Status: 35% engineering design plans completed

Total Cost: \$86,250

Related Development Projects: Hub park and 11 Crown Street mixed use development

The TOD Multi-Modal Improvement Plan recommends the addition of several new transit bus stops in the TOD District. The City is seeking state funds to complete final design and construction of a bus pull-off on East Main Street at St. Casimir Drive. This work is designed to improve public transit bus access on the south side of the Hub site and also in proximity to the Perkins Square/South Colony Street and Crown Street area.

Overall, these projects will help the City achieve the long term goals and objectives include creating a dynamic downtown TOD center that promotes existing cultural resources within the City and creates a safe, healthy, vibrant, accessible, and income generating hub for Meriden residents and for residents and visitors from the Greater Hartford/New Haven region. In the near term, this project is intended to address the insufficient pedestrian and roadway system that exists in the area of downtown closest to the rail station, existing retail area, and new development sites.

- (3) A detailed description of the proposal including but not limited to, a project schedule, budget, and site plan, and how it relates to both the existing conditions and the future vision. Proposals**

**for construction projects should also include, as attachments, project cost estimates supporting the request for funding, construction drawings, and a list of required permits and approvals;**

The proposed project includes the completion of six (6) key tasks. All of the tasks are borne out of the Multimodal TOD Traffic Improvement Plan (35% design plans) and are key projects that will improve access to current and future development projects and will pave the way for the future implementation of two way traffic throughout the TOD zoning district.

### **Task 1. Construct roadway and sidewalk improvements on West Main Street from Route 71 (Cook Ave.) to Colony Street**

#### **Subtasks:**

- Reconstruct West Main Street from Colony St. to Route 71 (Cook Ave.) with new sidewalks and pavement
- Improve pedestrian, transit, commercial and vehicular access through the removal and modification of bumpouts.
- Add streetscape elements including colored pavement at key nodes, textured crosswalks and loading zones, wayfinding signage for motorists and pedestrians, plantings and cobble tree protection.
- Remove one traffic signal, make minor modifications to two signals, and major modifications to one signal.
- Coordinate sidewalk and road closures with key property owners and tenants including Middlesex Community College, Meriden YMCA, Meriden Police Dept., CT Superior Court, and over 30 local merchants and property owners.
- Convert West Main Street from one-way to two-way from Colony Street to Cook Ave. (note two way configuration will we implemented in a future phase)

### **Task 2. Construct roadway and sidewalk improvements on Colony Street from East / West Main Street to Cross Street**

#### **Subtasks:**

- Improve pedestrian and vehicular access through the removal and modification of bumpouts
- Add streetscape elements including colored pavement at key nodes, textured crosswalks and loading zones, wayfinding signage for motorists and pedestrians, plantings and cobble tree protection.
- Allow traffic on state Route 71 to remain on the state road rather than diverted to local roads.
- Make minor modification to one traffic signal.
- Construct sidewalk improvements at 24 Colony Street development project that includes 63 residential units, 11,000 sf retail, and a 273-space parking garage
- Construct sidewalk system to \$20 million Meriden Transit Center, provide pedestrian access to Transit Center via 25-33 Colony Street

### **Task 3. Convert Route 71 (Cook Ave.) from Hanover St. to West Main Street from one-way to two-way traffic**

#### **Subtasks:**

- Make major modifications to two existing traffic signals, and includes new sidewalks at the intersections and new pavement.
- Improve access to 72 Cook Ave, a recently completed 6,000 sf adaptive reuse of commercial structure into laundromat and retail facility.
- Improve access to 116 Cook Ave./Former Factory H and future development of 184 residential

- units, \$55 million total development costs (proposed by POKO Partners LLC, 2015)
- Improve access to 1 King Place, 300,000 sf structure on 5.6-acre brownfield site.
- Remove two traffic islands.

#### **Task 4. Install bus pull-off on East Main Street at Pratt Street & St. Casimir Drive**

Subtasks:

- Finalize engineering design plans
- Improve access to the Hub site, South Colony Street and 11 Crown Street via public transit

#### **Task 5. Complete Site restoration at 33-51 South Colony Street**

Subtasks:

- Widen sidewalks and add crosswalks on South Colony St. to improve pedestrian mobility
- Remove building slab and add temporary landscaping at 33-51 South Colony (City owned)
- Improve access from the Meriden Transit Center and Hub site to 11 Crown Street and future development of \$27 million project, including demolition of existing structure and construction of 81 housing units (proposed by The Michaels Organization, 2015)
- Convert one way to two way traffic flow (future phase)

#### **Task 6. Complete Sidewalk Restoration and Street Paving on State Street near MTC**

Subtasks:

- Construct new sidewalks and paving adjacent to the Hub park and Meriden Transit Center
- Improve pedestrian and bicycle access to Meriden Transit Center, Hub, and future development at 161-177 State Street, a \$24 million, 75-unit mixed use development including 7500 sf of commercial/retail space to be constructed by Penrose

### **Statement of Work & Project Readiness**

#### **A. Preliminary Design (completed March 2014)**

The City, along with design consultant CDM Smith, has completed Preliminary Design Plans for the roadway network surrounding the Meriden Transit Center and other designated streets. The work is within existing curb limits in a majority of the project. Pedestrian and bicycle accommodations are being provided as part of the preliminary design to facilitate movements into the Meriden Transit Center. There are no significant impacts anticipated to drainage and utilities within the project limits. The design is based on state and local standards. Funding for this activity was provided by the Connecticut Department of Transportation under a 2012 Transit Oriented Development Pilot Grant. Completed activities include:

- 35 percent design plans
- General Roadway Plans
- Traffic Management Details
- Traffic Signal Control Plans
- Pavement Marking and Signage Plans
- Streetscape Plans
- Preliminary Quantity and Cost Estimate

- Preliminary Set of Specifications
- Wayfinding/Signage Plan (1" = 100' scale)
- Preliminary Design Checklist and report

**B. NEPA/CEPA Review-Preliminary Design Plans & Final Design Plans (substantially completed)**

The City contracted with CDM Smith to complete an Environmental Review of the Preliminary Design Plans. Analysis completed by the City suggests that these projects qualify for a Categorical Exclusion (CE) under both NEPA and CEPA for the following reasons:

- Improvements are within existing disturbed areas and primarily within existing curb limits (the only exception being a small area of an existing commercial parking lot that will be acquired to meet road design standards)
- No sensitive features (e.g., wetlands, endangered species, historic or archaeological resources) will be affected by the improvements

CDM Smith's review found that Per Section 22a-1a-4 of the Regulations of Connecticut State Agencies, the proposed projects will qualify as typical roadway projects which does not warrant a review under CEPA. The construction project will be limited to the following activities:

- Reconstruction activities on the existing roadway
- Correcting existing substandard roadway geometrics and intersections, such as turn lanes, improved turning radii, correcting vertical or horizontal slopes, divisional and refuge islands, and installation of curbs and gutters
- Modifications to or addition of sidewalks, curbs and streetscape amenities.

Appropriate mitigation measures will be employed during project construction to minimize noise and air quality impacts to abutters, control erosion and minimize traffic disruption. Once constructed, the improvements will address the projected increases in traffic resulting from new rail service while providing a safe and efficient local transportation network for city residents and business that operate downtown. All improvements will incorporate innovative design for maintenance and environmental sensitivity while allowing for safe and efficient flow of vehicular traffic, pedestrians, and bicyclists to the Meriden Transit Center. Immediately following the approval of this grant application, the City will proceed with completion of a joint NEPA/CEPA Categorical Exclusion, if required. The City expects that the completion of the NEPA/CEPA review will not cause delays to the implementation schedule. The City will also initiate the permitting process and anticipates obtaining all necessary approvals.

**C. Final Design Plans**

The City will issue a contract extension to CDM Smith to prepare final design plans for Cook Ave., South Colony Street and the East Main Street transit bus pullout. Final design plans are completed for West Main Street, Colony Street and State Street.

**D. Construction**

The City will seek bids from qualified contractors to construct the roadway improvements outlined in this proposal. Procurement of qualified contractors will be managed by the City's Purchasing Office, which is well qualified and has a demonstrated track record of managing procurements of this type and at comparable scale. Projects may be completed by one or more contractors over an estimated 18-month construction phase. Construction of the proposed traffic improvements will utilize Smart Growth and Complete Streets principles to facilitate access to the Meriden Transit Center, create a more attractive, vibrant and walkable downtown and attract transit-oriented development. The successful contractor will



be required to use sustainable strategies to provide for a better quality of life and cleaner environment for city residents and workers. Agreements with contractors will be done in compliance with all applicable local, state and federal requirements.

**E. Project Inspection/Management**

The City will arrange for independent inspections of all construction activities and management of construction contractors.

**F. Project Administration & Management-City of Meriden**

The City will retain staff to manage and oversee the project, including

- Provide engineering staff to oversee the implementation of the Project and oversee completion of all tasks included in the Scope of Work
- Manage the grant agreements as required. The City of Meriden Office of Economic Development will take the lead in administering the grant funds. The Economic Development staff is well qualified to manage the project and has a demonstrated track record in managing similar grant programs, including the 2012 TOD Pilot Grant Project and the 2015 TOD Planning Grant.
- Provide project oversight and direction to the project so that ultimately the project implementation is consistent with the City of Meriden’s long range goals, vision and financial capacity.

**G. Planning Approvals**

The City has completed final engineering design plans for West Main and Colony Streets. Final designs will be completed for Cook Ave. and the East Main Street transit bus stop. City will use standard bid specifications for sidewalk improvements on State Street, Pratt Street and East Main Street and typical demo specifications for the removal of the slab and construction of replacement sidewalks at 33-51 S. Colony Street. Once the construction funds are in place for the remaining phases, the City will complete final design and begin construction within 12 months and complete the project in 24 months. The project was included on the SCRCOG TIP in 2015 and can be added as an amendment to the 2015-2018 TIP if required.

**(H) Project Budget**

A summary of the budget is outlined below. A detailed budget has been included as an attachment. The cost estimates were developed by CDM Smith and verified by the City of Meriden engineering staff based on comparable projects completed by the City of Meriden.

Task	Budget
West Main Street	\$621,000
Colony Street	\$512,900
State Street	\$735,489
Cook Ave.	\$750,000
Perkins/S. Colony Streets	\$274,500
East Main Bus Stop	\$86,250
<b>Total</b>	<b>\$2,980,139.00</b>
City Share	\$980,139.00/33% (approved prior years CIP)
State Share	\$2,000,000.00/67% (proposed TOD grant)

**(4) A description of how the proposal will support TOD and/or responsible growth**

The City's goal is to transform the Meriden Transit Center (MTC), the adjacent 14-acre Hub brownfield site, and the half-mile area surrounding it into a modern, urban area that offers mixed-use and transit oriented development, a pedestrian friendly environment, new residential and commercial areas, public open space, and improved access to public transportation. We have in our sights a five-year plan to foster the development of 600-1000 housing units in the TOD district and provide viable housing choices and employment options for residents that choose to move to Meriden's TOD district. By providing both new and affordable housing in our TOD district and within walking distance to the Meriden Transit Center, CT Transit bus service, and new commuter rail service, 140,000 jobs will be located within within a 40-minute commute. Long term benefits to the City of Meriden include a projected investment of \$125 million in mixed-use development resulting in a total of 1,107 direct, indirect and induced full and part-time jobs and \$7.5 million in State and local taxes.

**(5) A brief assessment of what is considered to be the most critical hurdle(s) to overcome in order to realize the municipality's vision, and to what extent, if any, state agencies might be needed to facilitate a coordinated solution.**

While we will strive to attract young workers and empty nesters seeking high quality affordable and workforce housing, we have two critical hurdles that must be addressed to make this effort truly successful. First, we once had major private sector employers such as Insilco, New Departures and others who employed thousands in the neighborhood. That is not the case today as the major employers located downtown are primarily governmental or non-profit entities including the City of Meriden, Middlesex Community College and the Community Health Center. The City and state must partner with the private sector to ensure that future development in downtown Meriden and in the region is populated with employers that hire workers that choose to live in the Meriden TOD.

Second, Meriden's TOD District includes residential neighborhoods and commercial areas most affected by the decline of the silver manufacturing industry and the associated job loss, economic disinvestment, and environmental hazards. The area population is predominantly low income, transient, non-white, and under educated. The City and its public and private partners need to ensure that "ladders up" are provided so these residents can take full advantage of transportation improvement and job access opportunities associated with the improvements in transportation infrastructure.

In 2015, the City completed the Choice Neighborhoods Transformation Plan, which is a comprehensive plan to improve the downtown neighborhood in terms of education and employment opportunities, housing, transportation, health, safety and overall quality of life. The City will continue to address and implement the strategies of the Choice Neighborhoods Transformation Plan through the five working groups (healthy Meriden, TOD/traffic, safety, education and employment) that will meet regularly and report back on progress to HUD, City Council and the Meriden Housing Authority over the next 24 months.

For additional information, please contact:

Lawrence J. Kendzior, City Manager  
City of Meriden, 142 East Main Street  
Meriden, CT 06450  
[lkdenzior@meridenct.gov](mailto:lkdenzior@meridenct.gov)  
203 630 4123

Juliet Burdelski  
Director of Economic Development  
City of Meriden, 142 East Main Street  
Meriden, CT 06450  
[jburdelski@meridenct.gov](mailto:jburdelski@meridenct.gov)  
203 630 4152

Attachments:

1. **Budget**
2. **SCRCOG Resolution**
3. **Photos of Project Area**
4. **Draft Planning Permitting Plan**
5. **Schedule**
6. **Project Area Map and Location of Proposed Construction Projects**
7. **Construction drawings**
8. **City Council Resolution**

1. Detailed Project Budget-by task. The cost estimates included in the budget were developed by CDM Smith and verified by the City of Meriden engineering staff based on comparable work completed in the City of Meriden.

Task #	Project	Design					Construction	Traffic (7.5%)	Inspection (7.5%)	Total
<b>1.a</b>	<b><u>West Main Street</u></b>									
	<u>Sidewalks, Bumpout Removal, Signal Removal at Barristers Court</u>		L ft	W ft	Unit price	unit				
	Estimate Construction Date - 5/1/16 - 9/1/16	\$111,682								
	W Main St - south side (S Grove St to Colony St)		600	10	\$16.00	sf	\$96,000	\$7,200	\$7,200	\$110,400
	W Main St - north side (Butler St to Colony St)		1200	15	\$16.00	sf	\$288,000	\$21,600	\$21,600	\$331,200
	Colony St to Church St		650	15	\$16.00	sf	\$156,000	\$11,700	\$11,700	\$179,400
										<b>\$621,000</b>

<b>1.b</b>	<b><u>Colony Street</u></b>									
	Church to Columbia - west side		L ft	W ft	Unit price	unit	Construction	Traffic (7.5%)	Inspection (7.5%)	Total
	Church to Washington - color band	\$0	200	10	\$16.00	sf	\$32,000	\$2,400	\$2,400	\$36,800
	Washington to Columbia - plain	\$0	1650	10	\$12.00	sf	\$165,000	\$12,375	\$12,375	\$189,750
	Church to Camp - east side									
	Church to Brooks - color band	\$0	500	15	\$16.00		\$120,000	\$9,000	\$9,000	\$138,000
	Brooks to Camp 1,075' x 10' wide x \$10/sf = \$107,500		1075	10	\$12.00		\$129,000	\$9,675	\$9,675	\$148,350
										<b>\$512,900</b>

2	<u>State Street &amp; Hub site</u>		L ft	W ft	Unit price	unit	Construction	Traffic (7.5%)	Inspection (7.5%)	Total
	Reconstruct sidewalks around HUB State St (east side) / East Main St (north side) / Pratt St (west side)		3200	10	\$12.00		\$384,000	\$28,800	\$28,800	\$441,600
	State Street paving from Camp Street to East Main Street		2300	50	\$20.00	sy	\$255,556	\$19,167	\$19,167	\$293,889
										<b>\$735,489</b>

3	<u>Cook Avenue Two-Way Conversion</u>	Design	# signals	Cost/signal			Construction	Traffic (7.5%)	Inspection (7.5%)	Total
	2 signals (Cook Ave at Hanover St, Cook Ave at West Main Street) and geometric improvements - new construction.	\$60,000	2	\$300,000			\$600,000	\$45,000	\$45,000	\$750,000

4	<u>Perkins Square/S. Colony/Crown St</u>	Design					Construction	Traffic (7.5%)	Inspection (7.5%)	Total
	Church / Morse wall demo and temp landscaping	\$15,750					\$225,000	\$16,875	\$16,875	\$274,500

							Construction	Traffic (7.5%)	Inspection (7.5%)	Total
5	<u>East Main Street bus stop</u>	\$0					\$75,000	\$5,625	\$5,625	\$86,250

**TOTAL:**

Design	Construction	Traffic (7.5%)	Inspection (7.5%)	Total	State Share	City Share
\$187,432	\$2,525,556	\$189,417	\$810,417	\$2,980,139	\$2,000,000 (67%)	\$980,139 (33%)

## 2. SCRCOG Resolution



**SOUTH CENTRAL REGIONAL COUNCIL OF GOVERNMENTS**

*Planning for Our Region's Future*

---

Bethany Branford East Haven Guilford Hamden Madison Meriden Milford  
New Haven North Branford North Haven Orange Wallingford West Haven Woodbridge

---

Carl J. Amento, Executive Director

### **Resolution in Support of the City of Meriden's Application to the Responsible Growth and Transit-Oriented Development (TOD) Grant Program**

**Whereas:** The Connecticut Office of Policy and Management (OPM) has issued a Request for Applications (RFA) for the Responsible Growth and Transit-Oriented Development (TOD) Grant Program;

**Whereas:** The City of Meriden intends to submit an application in response to the RFA issued by OPM for the Responsible Growth and Transit-Oriented Development (TOD) Grant Program for the implementation of its Multi-Modal Roadway Improvement consistent with TOD as defined in Section 13b-79o of the Connecticut General Statutes;

**Whereas:** The application from the City of Meriden is consistent with the policies in both the State and Regional Plan of Conservation and Development of revitalizing existing centers, improving access and connectivity, and increasing the sustainability of the transit system;

**Whereas:** The application from the City of Meriden seeks to increase transit ridership, economic and housing opportunities, infrastructure improvements and connectivity in downtown Meriden through the implementation of its Multi-Modal Roadway Improvement including the construction of surface transportation infrastructure in downtown Meriden; and

**Whereas:** The application from the City of Meriden will leverage the SCRCOG Regional TOD Feasibility Study and municipal studies previously completed and \$100 million in private investment in mixed use development in the City of Meriden TOD District.

### **Now, Therefore, Be It Resolved By the South Central Regional Council of Governments (SCRCOG) that:**

SCRCOG supports the City of Meriden's application to apply for funding under the Responsible Growth and Transit-Oriented Development (TOD) Grant Program as it meets the region's goals of increasing transit ridership, increasing economic and housing opportunities and improving connectivity and access around transit.

The undersigned duly qualified and acting Secretary of the South Central Regional Council of Governments certifies that the foregoing is a true and correct copy of a resolution adopted at a legally convened meeting of the South Central Regional Council of Governments on **January 27, 2016**.

Date: **January 27, 2016**

By:

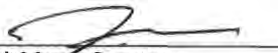
  
Joseph Mazza, Secretary  
South Central Regional Council of Governments

---

127 Washington Avenue, 4th Floor West, North Haven, CT 06473

www.scrcog.org T (203) 234-7555 F (203) 234-9850 camento@scrcog.org

3. Photos of Project Area



Photos (clockwise): 1) State Street sidewalks next to Hub park to be reconstructed, 2) Colony Street sidewalks to be reconstructed, 3) South Colony Street sidewalks and former Church and Morse & Liseo building slabs (to be removed), 4) West Main Street sidewalks to be reconstructed

Photos of Project Area



1) Park at the Hub site



3) W. Main Sidewalks at Grove St.



2) W. Main Sidewalks at Grove St



3) 24 Colony Street Mixed Use

Photos (clockwise): 1) Park at the Hub site, 2) West Main Street curb (constructed in 2015), 3) 24 Colony Street Mixed Use Development, 4) West Main Street sidewalk and bumpout removal (constructed in 2015)



## 4. Draft Planning Permitting Plan

### Overview

The City of Meriden recognizes the importance of demonstrating project readiness and is confident that all federal, state and local approvals will be obtained for the proposed roadway improvements. This memorandum describes the permitting requirements and status of the proposed work.

### National Environmental Policy Act (NEPA) and Connecticut Environmental Policy Act (CEPA) Compliance

Implementation of the roadway improvement program is necessary for safe and efficient access is provided for users of the Meriden Transit Center and NHHS rail system. The City believes that the project qualifies as a Categorical Exclusion (CE) under both NEPA and CEPA for the following reasons:

- Improvements are within existing disturbed areas and primarily within existing curb limits (the only exception being a small area of existing commercial parking lot that will be acquired to meet road design standards)
- No sensitive features (e.g., wetlands, endangered species, historic or archaeological resources) will be affected by the improvements. The City will prepare complete documentation justifying that the project qualifies as a CE pursuant to NEPA and CEPA in advance of construction. Preliminary justification is provided below.

Pursuant to NEPA, the action qualifies as a CE because it does not involve:

- The acquisition of more than minor amounts of temporary or permanent strips of right-of-way for construction of such items as clear vision corners and grading. Such acquisitions will not require any commercial or residential displacements.
- The use of properties protected by Section 4(f) of the Department of Transportation Act (49 U.S.C 303).
- A determination of adverse effect by the State Historic Preservation Officer. *While the project improvements are in the vicinity of historic structures, there will be no impacts as a result of the roadway improvements.*
- Any U.S. Coast Guard construction permits or any US Army Corps of Engineers Section 404 permits
- Any work in wetlands. *Harbor Brook is located adjacent to the proposed project area. However, due to all proposed work being within existing roadway footprints, no impacts to wetland resource areas are anticipated as a result the project.*
- Any work encroaching on a regulatory floodway or any work affecting the base floodplain (100-year flood) elevations of a water course or lake. *While the roadway improvements are within the 100-year floodplain, there will be no changes in drainage patterns or stormwater flows. No filling or excavating is proposed. Existing curb lines will be matched.*
- Construction in, across or adjacent to a river designated as a component or proposed for inclusion in the National System of Wild and Scenic Rivers published by the US Department of the Interior/US Department of Agriculture.
- Any changes in access control. The use of a temporary road, detour or ramp closure. *There may be lane restrictions on existing roadways during construction.*
- Any known hazardous materials sites or previous land uses with potential for hazardous materials remains within the right-of-way.
- Any work within farmland protected under the Farmland Protection Policy Act. *This project is proposed on Udothents Urban land complex and urban land soils. There are no protected farmland soils located within the project area.*

- Work within Airport Clear Zones or Accident Potential Zones. *The closest airport to the proposed project location is Meriden Markham Municipal Airport approximately 2.5 miles southwest. This project is not proposed within Airport Clear Zones or Accident Potential Zones.*

In addition, the proposed action:

- Conforms to the Air Quality Implementation Plan which is approved or promulgated by the Environmental Protection Agency in air quality non-attainment areas
- Is not within the coastal zone
- Occurs in an area where there are no federally listed endangered or threatened species or critical habitat.

**Pursuant to the FHWA implementing procedures at 23 CFR 771.117:**

CEs are actions which meet the definition contained in 40 CFR 1508.4, and, based on past experience with similar actions, do not involve significant environmental impacts. They are actions which: do not induce significant impacts to planned growth or land use for the area; do not require the relocation of significant numbers of people; do not have a significant impact on any natural, cultural, recreational, historic or other resource; do not involve significant air, noise, or water quality impacts; do not have significant impacts on travel patterns; or do not otherwise, either individually or cumulatively, have any significant environmental impacts.

Per Section 22a-1a-4 of the Regulations of Connecticut State Agencies, the proposed action qualifies as a typical roadway project which does not warrant a review under CEPA:

- Reconstruction activities on the existing roadway
- Correcting existing substandard roadway geometrics and intersections, such as turn lanes, improved turning radii, correcting vertical or horizontal slopes, divisional and refuge islands, and installation of curbs and gutters
- Modifications to or addition of sidewalks, curbs and streetscape amenities.

Appropriate mitigation measures will be employed during project construction to minimize noise and air quality impacts to abutters, control erosion and minimize traffic disruption. These measures will be described in the CE documentation. Once constructed, the improvements will address the projected increases in traffic resulting from new rail service while providing a safe and efficient local transportation network for city residents and business that operate downtown. All improvements will incorporate innovative design for maintenance and environmental sensitivity while allowing for safe and efficient flow of vehicular traffic, pedestrians, and bicyclists to the Meriden Transit Center.

**Other Federal, State and Local Permits**

***Federal Permits***

Beyond a NEPA CE determination, no federal environmental permits are anticipated.

***State Permits***

***General Permit for the Discharge of Stormwater and Dewatering Wastewaters Associated with Construction Activities*** – Per Section 302 of the federal Clean Water Act, National Pollution Discharge Elimination System (NPDES) program, registration of the project under this permit would be required if the area of construction exceeds one acre. Total disturbed area for the proposed roadway improvements is anticipated to equal or exceed one acre, and therefore this permit will be required.

Connecticut is a delegated state, which means that permits that typically fall under the jurisdiction of the United States Environmental Protection Agency (EPA) are subject to review or are issued by the Connecticut Department of Energy and Environmental Protection (CT DEEP). A Notice of Intent (NOI), requesting coverage under the General Permit for this activity must be prepared and submitted to CT DEEP. Proper measures for the Storm Water Pollution Prevention Plan (SWPPP) consistent with State stormwater and sediment/erosion control measures must be incorporated into the project design. The SWPPP must be prepared prior to submitting the NOI. The contractor will be required to implement the

stormwater and sediment control measures included in the SWPPP. A general permit must be in-place before construction begins.

***Flood Management Certification*** – Since much of the proposed roadway improvements are located within a designated floodplain, this certification will be required from the CT DEEP.

***National Diversity Database (NDDDB) Review*** – CT DEEP maintains a database and corresponding plans that track wildlife species, including those that are rare, threatened, or endangered. The project area was checked against this database to determine if any component of the project affects areas important to the existence of these species. There are no protected species within the limits of the project area.

***Connecticut State Historical Preservation Office (SHPO)*** – Although no impacts to historical features are anticipated, the SHPO must be contacted to confirm this conclusion.

#### ***Regional and Semi-Public Reviews, and Approvals***

Regional and semi-public agencies, including utility providers, must be contacted for project review and approvals.

***Utilities*** – since most of the recommended improvements involve work within the roadway right-of-way, they may affect existing underground electrical ducts, transmission mains, and/or overhead wires. This work must be approved by the owner of the existing utilities. Special design and/or construction provisions may be necessary to complete such work.

***Connecticut Natural Gas (CNG)*** – since most of the recommended improvements involve work within the right of way, they may require relocation of existing underground gas transmission mains. This work must be approved by CNG. Special design and/or construction provisions may be necessary to complete such work.

***Local Telephone Company*** – since most of the recommended improvements involve work within the right of way, they may require relocation of existing underground telephone, fiber optic, cable, and other related communications. This work must be approved by the local telephone company. Special design and/or construction provisions may be necessary to complete such work.

#### ***Local Permitting, Reviews, and Approvals***

All of the construction proposed under the recommended plan would occur within Meriden city limits and is not anticipated to require review by local agencies within the surrounding cities and towns.

***Meriden Inland Wetlands and Watercourses Agency (IWWA)*** – In Connecticut, state wetlands are regulated by corresponding municipalities. In the City of Meriden, IWWA reviews activities that may impact inland wetlands and watercourses in accordance with wetlands and watercourse regulations. The recommended roadway improvement project would require a permit from the IWWA for work within floodplain and possible Buffer Zone and/or Riverfront Area.

***City of Meriden Department of Public Works (DPW) Highway Division*** – this division of the DPW issues permits for all work that would be performed in the City right-of-way including, but not limited to: street opening, shoulder opening, sidewalk opening, and use of Right-of-Way. A permit from the Highway Maintenance Division of the DPW would likely be necessary for those improvements associated with the proposed roadway improvements project.

#### **Schedule for Achieving NEPA/CEPA Compliance and Obtaining Permits**

The City will proceed with completion of a joint NEPA/CEPA C, if required, immediately following the submittal of the grant application.

5. Project Schedule

Project Schedule - Traffic Improvements for City of Meriden Transit Oriented Development District	2016												2017												2018											
	JAN	FEB	MAR	APR	MAY	JUN	JUL	AUG	SEP	OCT	NOV	DEC	JAN	FEB	MAR	APR	MAY	JUN	JUL	AUG	SEP	OCT	NOV	DEC	JAN	FEB	MAR	APR	MAY	JUN	JUL	AUG	SEP	OCT	NOV	DEC
<b>2016 Sidewalks, Bumpout Removal, Signal Removal at Barristers Court</b>																																				
New sidewalks / Remove bumpouts on West Main Street -South Side S Grove to Colony																																				
New sidewalks / Remove bumpouts on West Main Street -north side Butler to Colony																																				
Colony St to Church St																																				
<b>Sidewalks - Colony Street</b>																																				
Church to Columbia - west side																																				
Church to Camp - east side																																				
<b>Sidewalks - HUB</b>																																				
State St (east side)																																				
East Main St (north side)																																				
Pratt St (west side)																																				
<b>State Street paving</b>																																				
Camp Street to East Main Street																																				
<b>Cook Avenue Two-Way Conversion</b>																																				
New signal Cook Ave at Hanover St																																				
New signal Cook Ave at West Main Street																																				
Two way conversion																																				
Church / Morse wall demo and temp landscaping																																				
East Main Street bus stop																																				



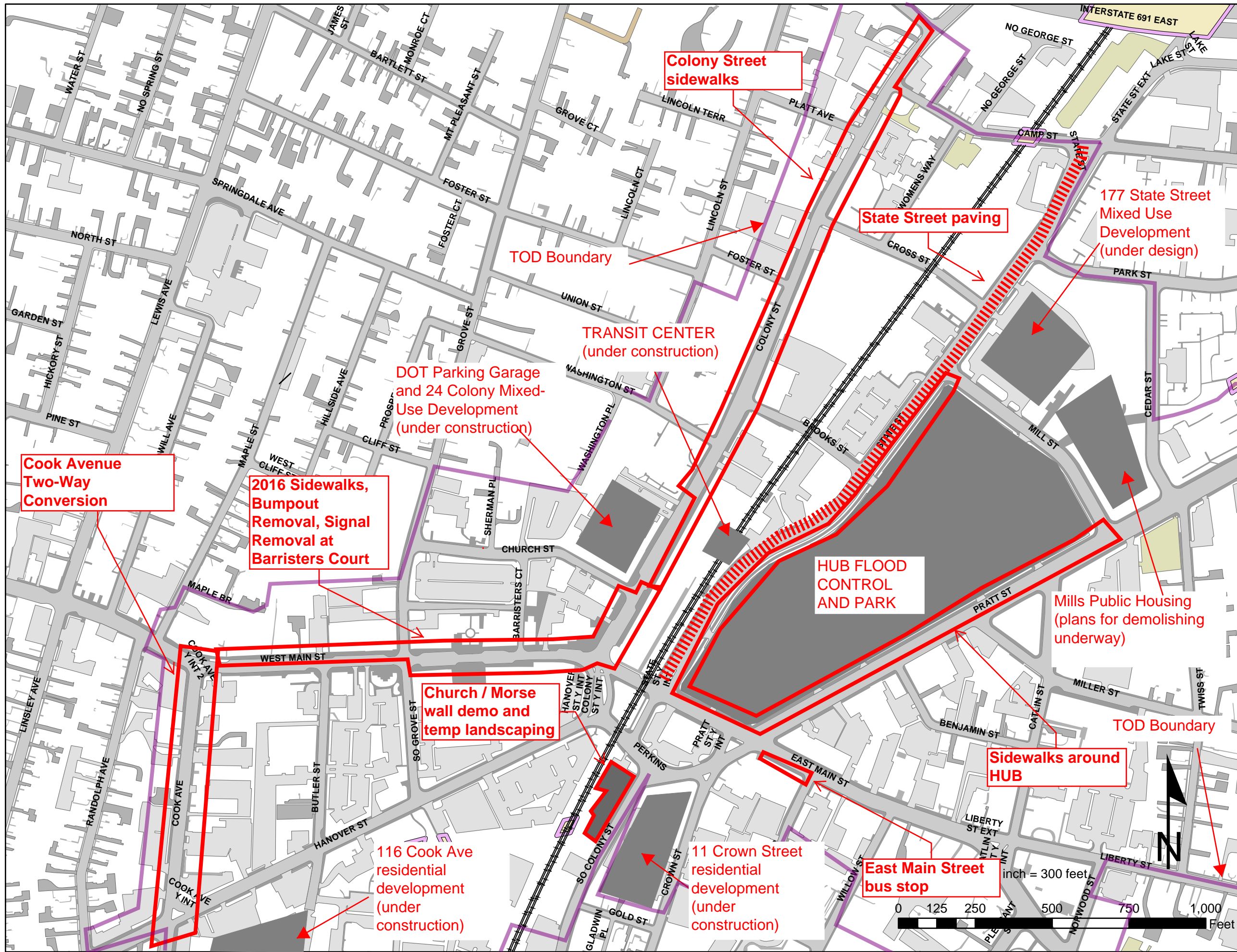

**BEGIN MILLING AND PAVEMENT OVERLAY.  
STA. 110+24 BL CONST. WEST MAIN ST.  
MATCH EXISTING GRADE**

**END MILLING AND PAVEMENT OVERLAY.  
MATCH EXISTING GRADE**

**NOTE:**  
SIDEWALKS TO BE RECONSTRUCTED. SEE  
FUTURE STREETSCAPE PLAN.

CURVE DATA	
CURVE 1 BL CONST. WEST MAIN ST.	
PI STA.	111+52.91 (N= 256785.99 E= 584140.45)
R=	330.00
Δ=	032° 50' 48"
D=	017° 21' 44"
T=	97.271
L=	189.184
PC STA.	110+58.32 (N= 256822.20 E= 584053.41)
PT STA.	112+47.50 (N= 256775.87 E= 584234.17)

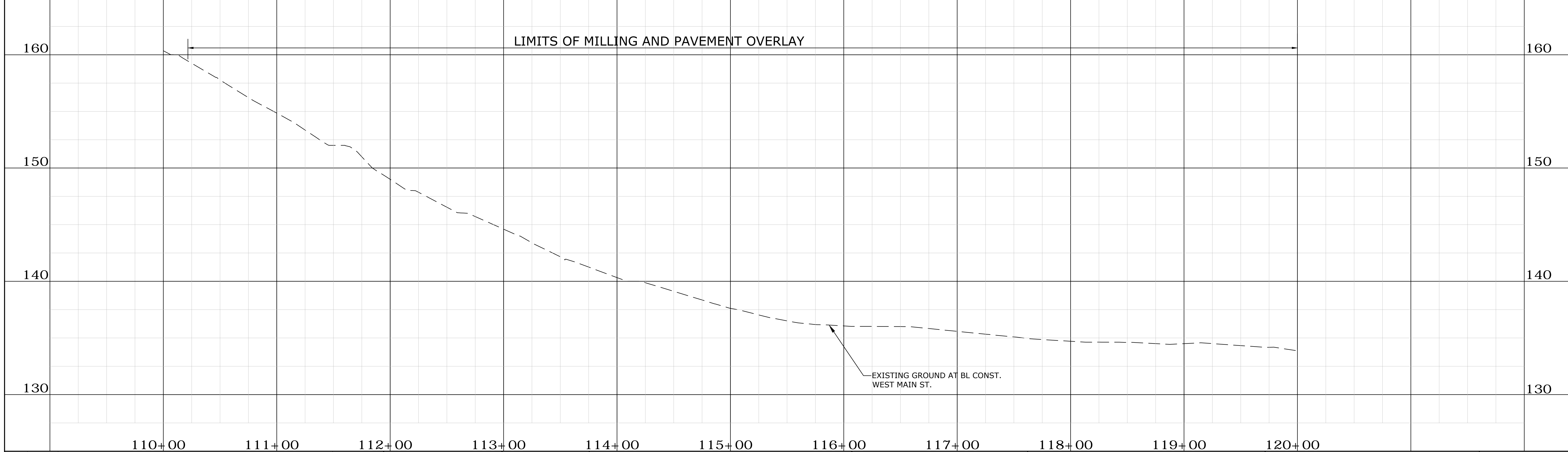
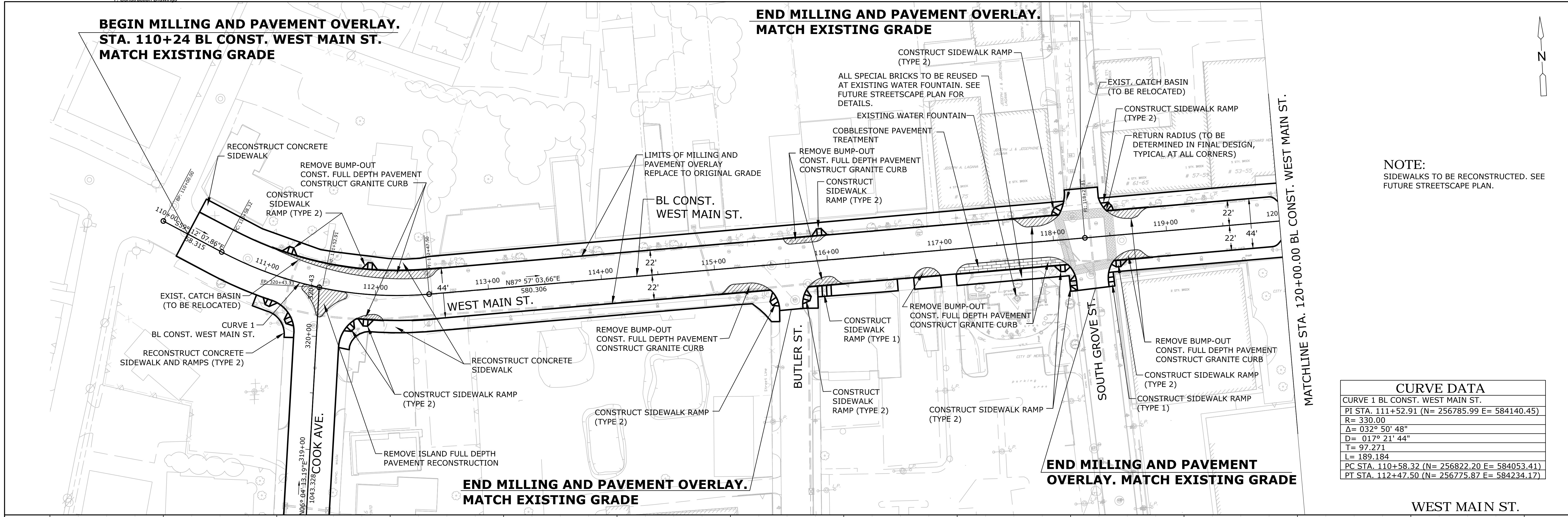

REV.	DATE	DESCRIPTION REVISIONS	SHEET NO.

HORIZONTAL SCALE (1" = 40')	DESIGNER: QLE
20 0 40	DRAFTER: HB
5 0 10	CHECKED BY: SK
VERTICAL SCALE (1" = 10')	DATE CHECKED:

**CDM Smith**

900 Chapel Street, Suite 1400  
New Haven, Connecticut 06510  
Phone: 203-865-2191  
Fax: 203-624-0484  
www.cdmsmith.com

ENGINEER:	APPROVED BY:	DATE:

PROJECT TITLE:	CADD	PLOTTED
TRAFFIC IMPROVEMENTS FOR TRANSIT ORIENTED DEVELOPMENT DISTRICT		

TOWN:	PROJECT NO.:
MERIDEN	0000-0000
DRAWING TITLE:	DRAWING NO.:
ROADWAY PLAN AND PROFILE (4)	PLN-04
	SHEET NO.:
	13

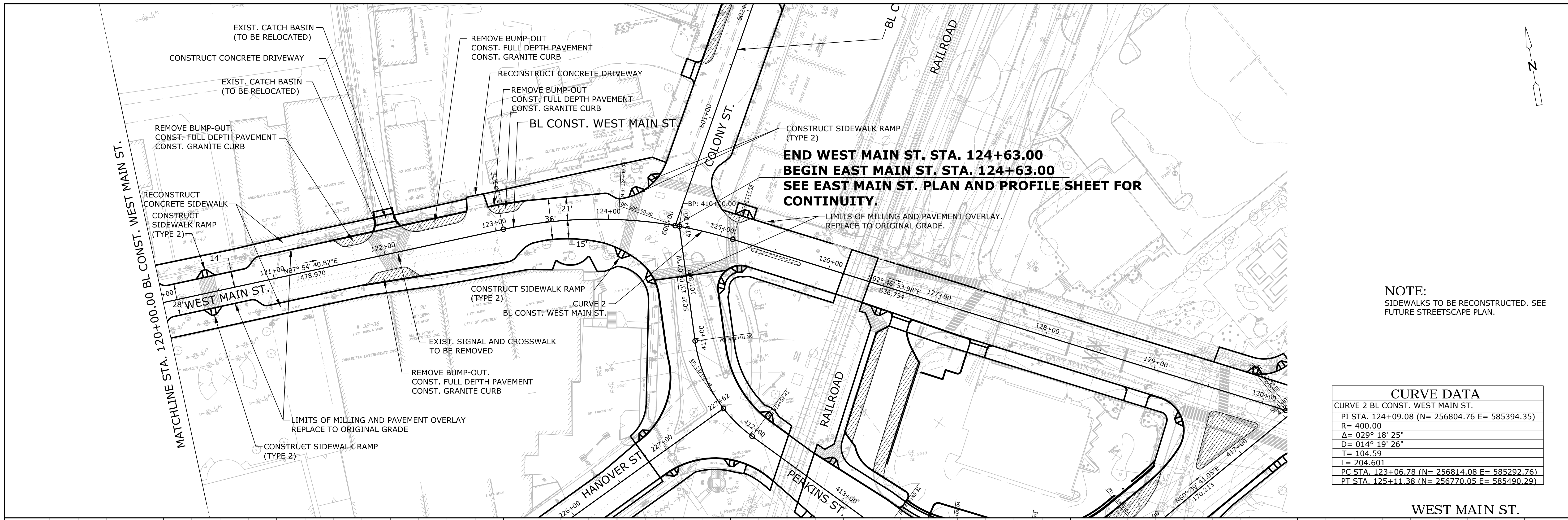

NOTE:  
SIDEWALKS TO BE RECONSTRUCTED. SEE  
FUTURE STREETScape PLAN.

CURVE DATA	
CURVE 2 BL CONST. WEST MAIN ST.	
PI STA.	124+09.08 (N= 256804.76 E= 585394.35)
R	400.00
Δ	029° 18' 25"
D	014° 19' 26"
T	104.59
L	204.601
PC STA.	123+06.78 (N= 256814.08 E= 585292.76)
PT STA.	125+11.38 (N= 256770.05 E= 585490.29)

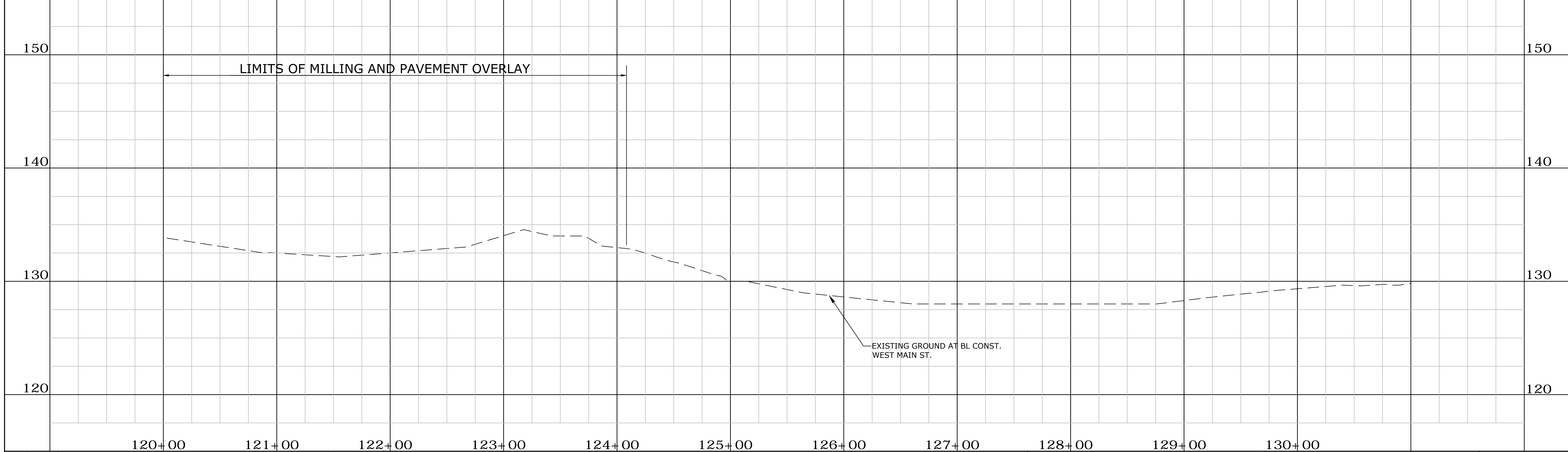

<table border="1"> <tr> <th>REV.</th> <th>DATE</th> <th>DESCRIPTION REVISIONS</th> <th>SHEET NO.</th> </tr> <tr> <td> </td> <td> </td> <td> </td> <td> </td> </tr> </table>	REV.	DATE	DESCRIPTION REVISIONS	SHEET NO.					<p>HORIZONTAL SCALE (1" = 40')</p> <p>VERTICAL SCALE (1" = 10')</p>	<p>DESIGNER: QLE</p> <p>DRAFTER: HB</p> <p>CHECKED BY: SK</p> <p>DATE CHECKED:</p>	<p>900 Chapel Street, Suite 1400 New Haven, Connecticut 06510 Phone: 203-865-2191 Fax: 203-624-0484 www.cdmsmith.com</p>	<p>ENGINEER:</p> <p>APPROVED BY:</p> <p>DATE:</p>	<p>PROJECT TITLE:</p> <p><b>TRAFFIC IMPROVEMENTS FOR TRANSIT ORIENTED DEVELOPMENT DISTRICT</b></p> <p>CADD</p>	<p>TOWN:</p> <p><b>MERIDEN</b></p> <p>DRAWING TITLE:</p> <p><b>ROADWAY PLAN AND PROFILE (5)</b></p> <p>PLOTTED -</p>	<p>PROJECT NO.:</p> <p>0000-0000</p> <p>DRAWING NO.:</p> <p><b>PLN-05</b></p> <p>SHEET NO.:</p> <p><b>14</b></p>
REV.	DATE	DESCRIPTION REVISIONS	SHEET NO.												

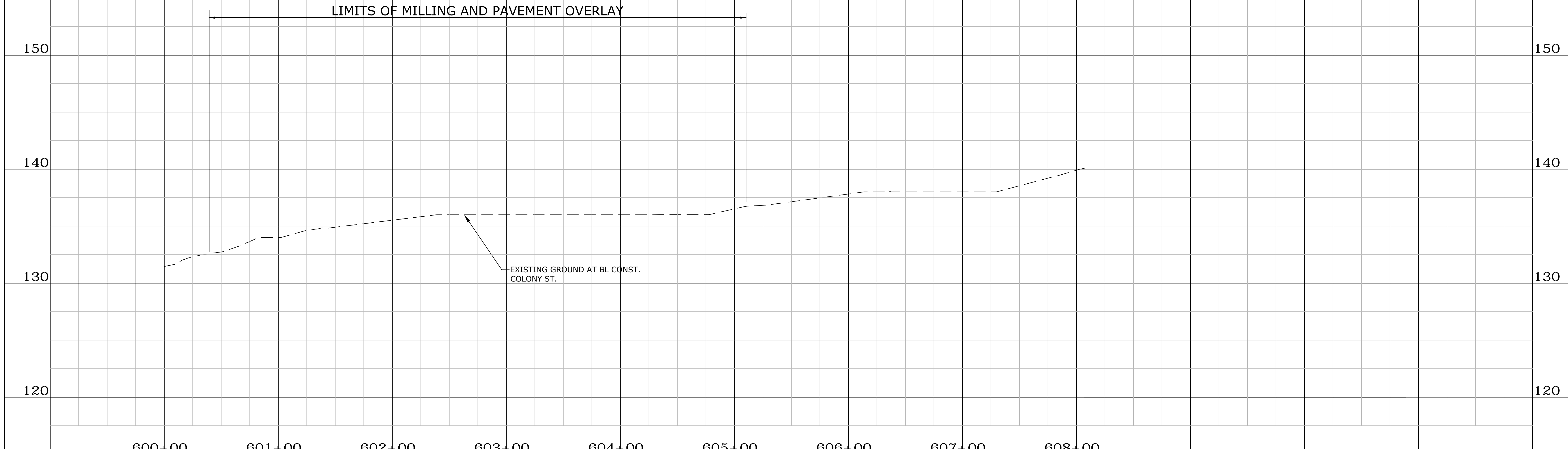
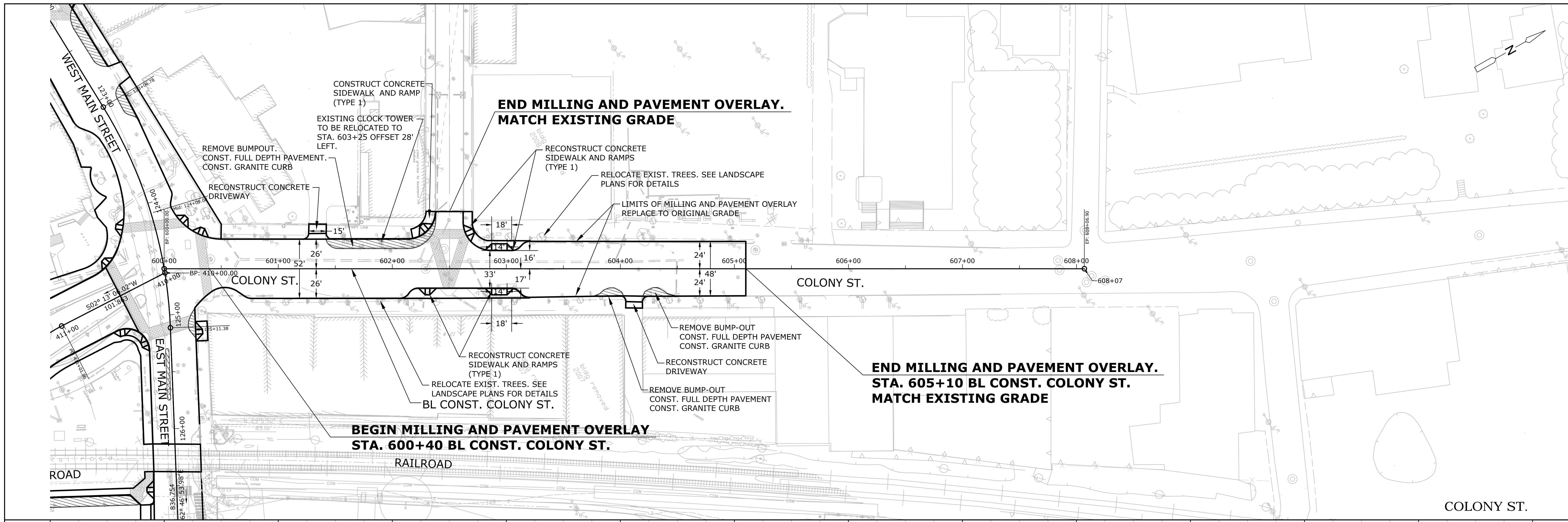

REV.	DATE	DESCRIPTION REVISIONS	SHEET. NO.

HORIZONTAL SCALE (1" = 40')

20 0 40

5 0 10

VERTICAL SCALE (1" = 10')

DESIGNER: QLE

DRAFTER: HB

CHECKED BY: SK

DATE CHECKED:

900 Chapel Street, Suite 1400  
 New Haven, Connecticut 06510  
 Phone: 203-865-2191  
 Fax: 203-624-0484  
 www.cdmsmith.com

ENGINEER:

APPROVED BY:

DATE:

PROJECT TITLE:

**TRAFFIC IMPROVEMENTS FOR TRANSIT ORIENTED DEVELOPMENT DISTRICT**

CADD

PLOTTED -

TOWN: MERIDEN

DRAWING TITLE: **ROADWAY PLAN AND PROFILE (07)**

PROJECT NO.: 0000-0000

DRAWING NO.: **PLN-07**

SHEET NO.: **16**



**BEGIN SIGNING AND PAVEMENT MARKINGS  
STA. 110+24 BL CONST. WEST MAIN ST.**

**END SIGNING AND PAVEMENT MARKINGS**

**END SIGNING AND PAVEMENT MARKINGS**

**END SIGNING AND PAVEMENT MARKINGS**

WEST MAIN ST.

**PAVEMENT MARKING LEGEND**  
 BWLL - 4in BROKEN WHITE LANE LINE  
 DYCL - 4in DOUBLE YELLOW CENTER LINE  
 SBL - 12in STOP BAR LINE (WHITE)  
 SWLL - 4in SOLID WHITE LANE LINE  
 SYL - 4in SOLID YELLOW LINE  
 WDEL - 4in WHITE DOTTED EXTENSION LINE

**NOTES:**  
 (T) BAR TYPE CROSSWALK  
 TOWN MAINTAINED

**END SIGNING AND PAVEMENT MARKINGS  
STA. 124+16 BL CONST. WEST MAIN ST.**

**END SIGNING AND PAVEMENT MARKINGS  
STA. 227+14 BL CONST. HANOVER ST.**

WEST MAIN ST.

REV.	DATE	DESCRIPTION REVISIONS	SHEET. NO.

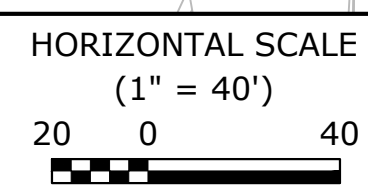

DESIGNER: SK  
 DRAFTER: LV  
 CHECKED BY: SK  
 DATE CHECKED:



900 Chapel Street, Suite 1400  
 New Haven, Connecticut 06510  
 Phone: 203-865-2191  
 Fax: 203-624-0484  
 www.cdmsmith.com

ENGINEER:  
 APPROVED BY: DATE:

PROJECT TITLE:  
**TRAFFIC IMPROVEMENTS FOR  
TRANSIT ORIENTED  
DEVELOPMENT DISTRICT**  
 CADD PLOTTED -

TOWN: **MERIDEN**  
 DRAWING TITLE:  
**SIGNING AND PAVEMENT  
MARKING PLANS**

PROJECT NO.: 131061-95916  
 DRAWING NO.: **SPM-03**  
 SHEET NO.: **24**

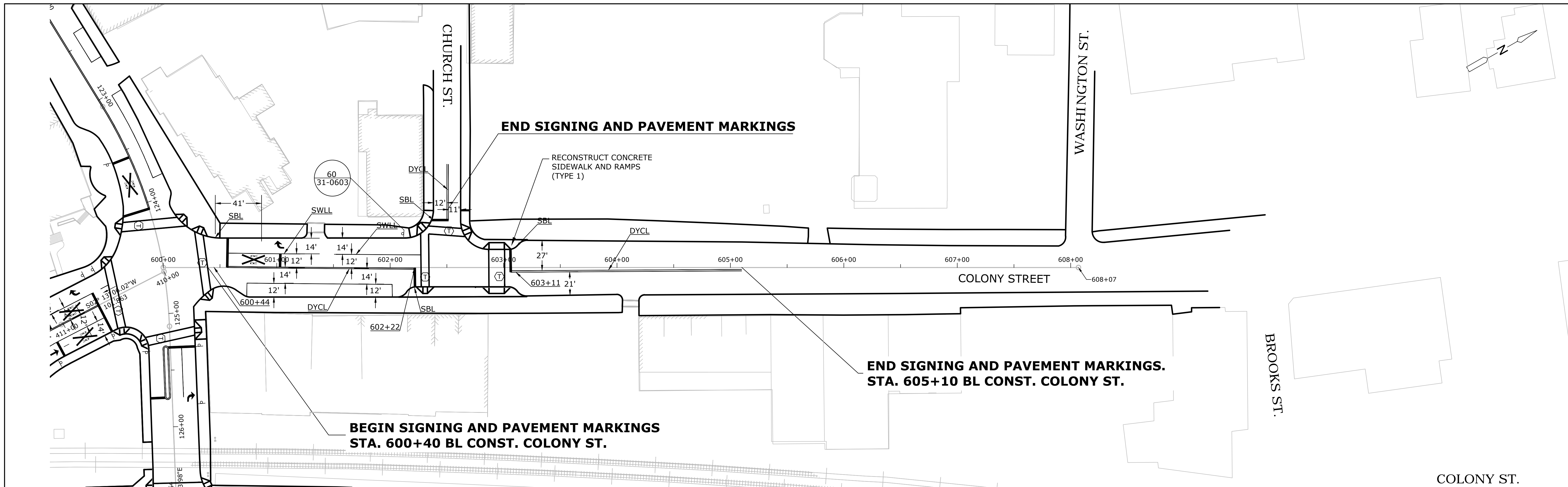

- PAVEMENT MARKING LEGEND**
- BWLL - 4in BROKEN WHITE LANE LINE
  - DYCL - 4in DOUBLE YELLOW CENTER LINE
  - SBL - 12in STOP BAR LINE (WHITE)
  - SWLL - 4in SOLID WHITE LANE LINE
  - SYL - 4in SOLID YELLOW LINE
  - WDEL - 4in WHITE DOTTED EXTENSION LINE

**NOTES:**  
 (T) BAR TYPE CROSSWALK  
 TOWN MAINTAINED

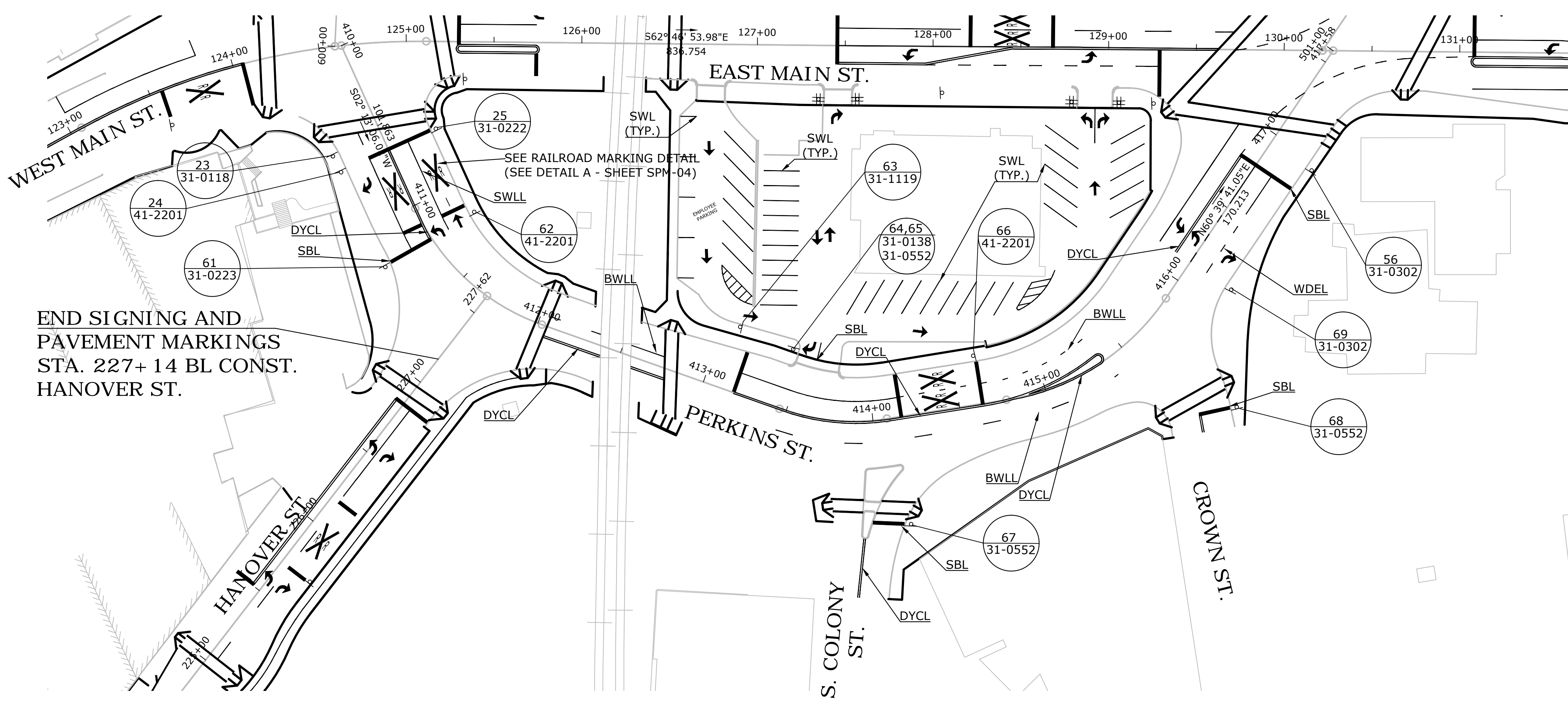

REV.	DATE	DESCRIPTION REVISIONS	SHEET. NO.

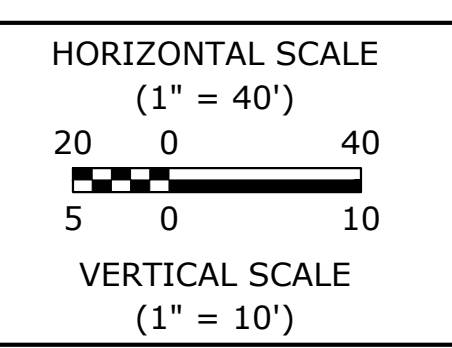

DESIGNER: SK  
 DRAFTER: LV  
 CHECKED BY: SK  
 DATE CHECKED:



900 Chapel Street, Suite 1400  
 New Haven, Connecticut 06510  
 Phone: 203-865-2191  
 Fax: 203-624-0484  
 www.cdmsmith.com

ENGINEER:  
 APPROVED BY:  
 DATE:

PROJECT TITLE:  
**TRAFFIC IMPROVEMENTS FOR  
 TRANSIT ORIENTED  
 DEVELOPMENT DISTRICT**  
 CADD  
 PLOTTED -

TOWN:  
**MERIDEN**  
 DRAWING TITLE:  
**SIGNING AND PAVEMENT  
 MARKING PLANS**

PERKINS ST.  
 PROJECT NO.:  
 131061-95916  
 DRAWING NO.:  
**SPM-05**  
 SHEET NO.:  
**26**



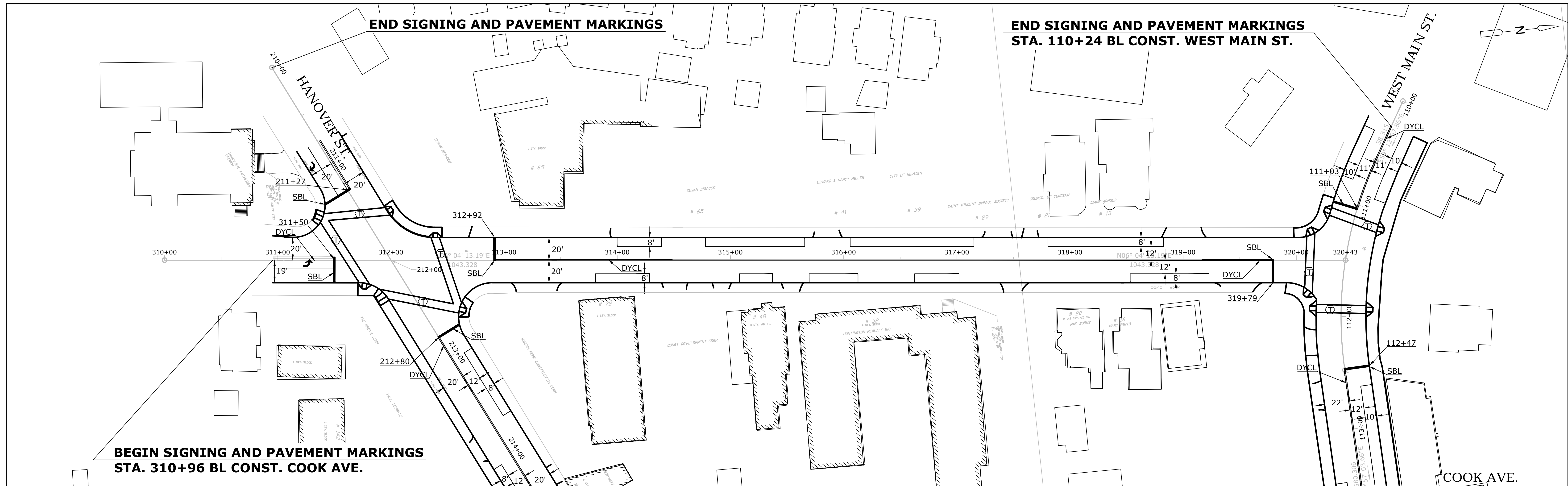

- PAVEMENT MARKING LEGEND**
- BWLL - 4in BROKEN WHITE LANE LINE
  - DYCL - 4in DOUBLE YELLOW CENTER LINE
  - SBL - 12in STOP BAR LINE (WHITE)
  - SWLL - 4in SOLID WHITE LANE LINE
  - SYL - 4in SOLID YELLOW LINE
  - WDEL - 4in WHITE DOTTED EXTENSION LINE

- NOTES:**
- BAR TYPE CROSSWALK
  - TOWN MAINTAINED

REV.	DATE	DESCRIPTION REVISIONS	SHEET. NO.

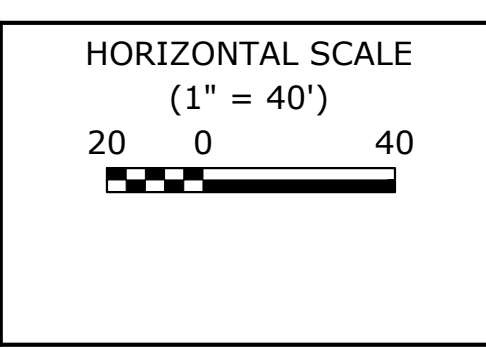

DESIGNER: SK  
 DRAFTER: HB  
 CHECKED BY: SK  
 DATE CHECKED:

900 Chapel Street, Suite 1400  
 New Haven, Connecticut 06510  
 Phone: 203-865-2191  
 Fax: 203-624-0484  
 www.cdmsmith.com

ENGINEER:  
 APPROVED BY:  
 DATE:

PROJECT TITLE:  
**TRAFFIC IMPROVEMENTS FOR  
 TRANSIT ORIENTED  
 DEVELOPMENT DISTRICT**

CADD      PLOTTED -

TOWN: **MERIDEN**

DRAWING TITLE:  
**SIGNING AND PAVEMENT  
 MARKING PLANS**

PROJECT NO.: 131061-95916  
 DRAWING NO.: **SPM-01**  
 SHEET NO.: **22**

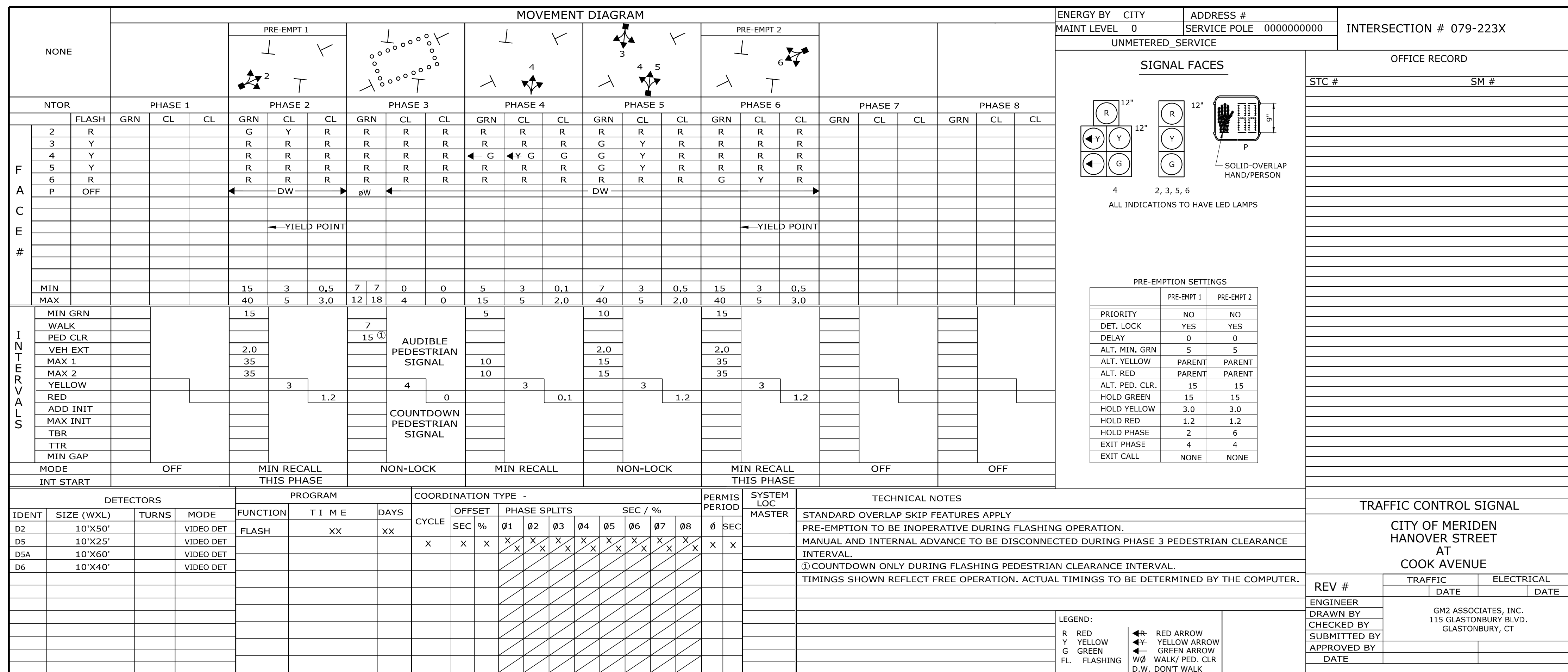

**CONSTRUCTION NOTES :**

ALL TRAFFIC SIGNAL EQUIPMENT IS EXISTING EXCEPT AS NOTED.

Ⓐ REMOVE OLD CONTROLLER AND INSTALL NEW CONTROLLER ON EXISTING FOUNDATION.

Ⓑ ALL TRAFFIC SIGNAL HEADS ARE NEW.

Ⓒ INSTALL NEW PEDESTAL WITH PEDESTRIAN SIGNAL FACE AND PUSH BUTTON.

Ⓓ REPLACE PEDESTRIAN SIGNAL FACE AND PUSH BUTTON. USE EXISTING PEDESTAL/MAST ARM POLE AND FOUNDATION.

REPLACE ALL OF THE WIRING.

CONTRACTOR TO REMOVE AND INSTALL SIGNING/PAVEMENT MARKINGS AS INDICATED ON SIGNING & PAVEMENT MARKING CONSTRUCTION PLAN.

FINAL LOCATION OF DETECTION AREAS FOR VIDEO DETECTION ZONE TO BE DETERMINED IN THE FIELD AND TO BE APPROVED BY THE CITY.

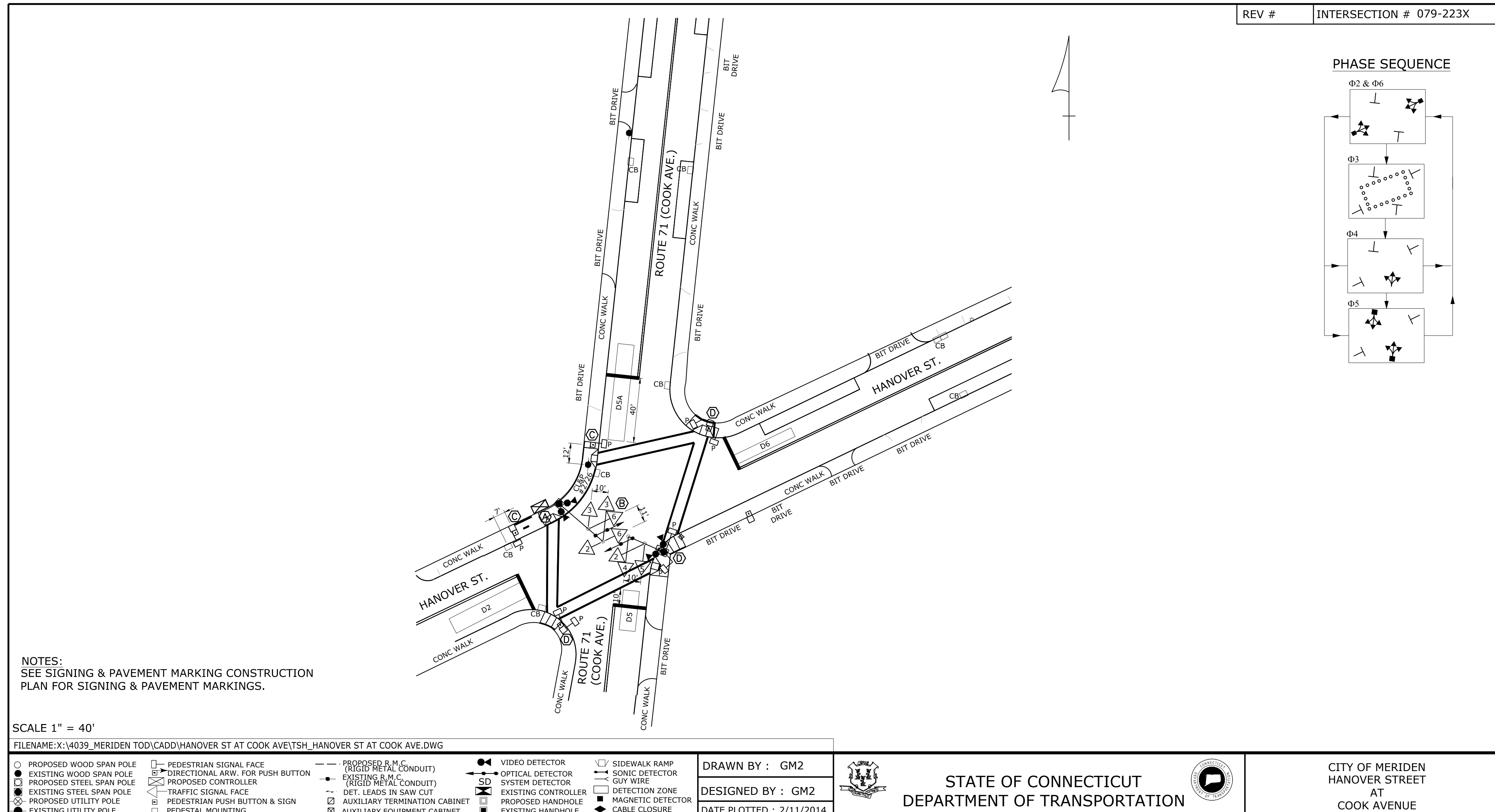

REV # INTERSECTION # 079-223X

NONE		MOVEMENT DIAGRAM																								ENERGY BY CITY	ADDRESS #
		PRE-EMPT 1						PRE-EMPT 2																		MAINT LEVEL	SERVICE POLE
																										UNMETERED_SERVICE	INTERSECTION # 079-236X
																										OFFICE RECORD	
																										STC #	SM #
NTOR	PHASE 1	PHASE 2		PHASE 3		PHASE 4		PHASE 5		PHASE 6		PHASE 7		PHASE 8													
2	Y	GRN	CL	CL	GRN	CL	CL	GRN	CL	CL	GRN	CL	CL	GRN	CL	CL	GRN	CL	CL								
4	R																										
6	Y																										
P	OFF																										

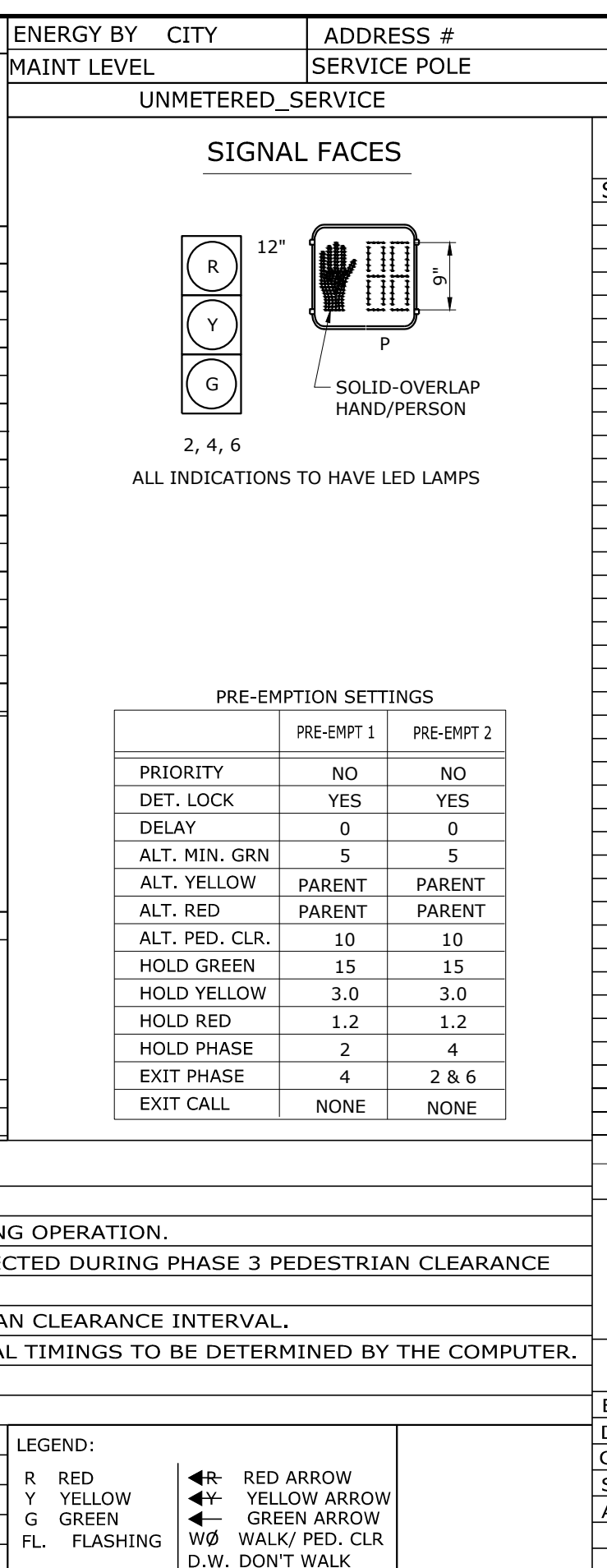

**CONSTRUCTION NOTES :**

- ALL TRAFFIC SIGNAL EQUIPMENT IS EXISTING EXCEPT AS NOTED.
- RELOCATE EXISTING PEDESTAL WITH DECORATIVE LUMINAIRE ON NEW FOUNDATION. INSTALL NEW PEDESTRIAN SIGNAL FACE AND PUSH BUTTON.
- REPLACE ALL PEDESTRIAN SIGNAL FACES AND PUSH BUTTON. USE EXISTING PEDESTAL/MAST ARM POLES AND FOUNDATION.

REPLACE ALL OF THE WIRING.  
CONTRACTOR TO REMOVE AND INSTALL SIGNING/PAVEMENT MARKINGS AS INDICATED ON SIGNING & PAVEMENT MARKING CONSTRUCTION PLAN.  
FINAL LOCATION OF DETECTION AREAS FOR VIDEO DETECTION ZONE TO BE DETERMINED IN THE FIELD AND TO BE APPROVED BY THE CITY.

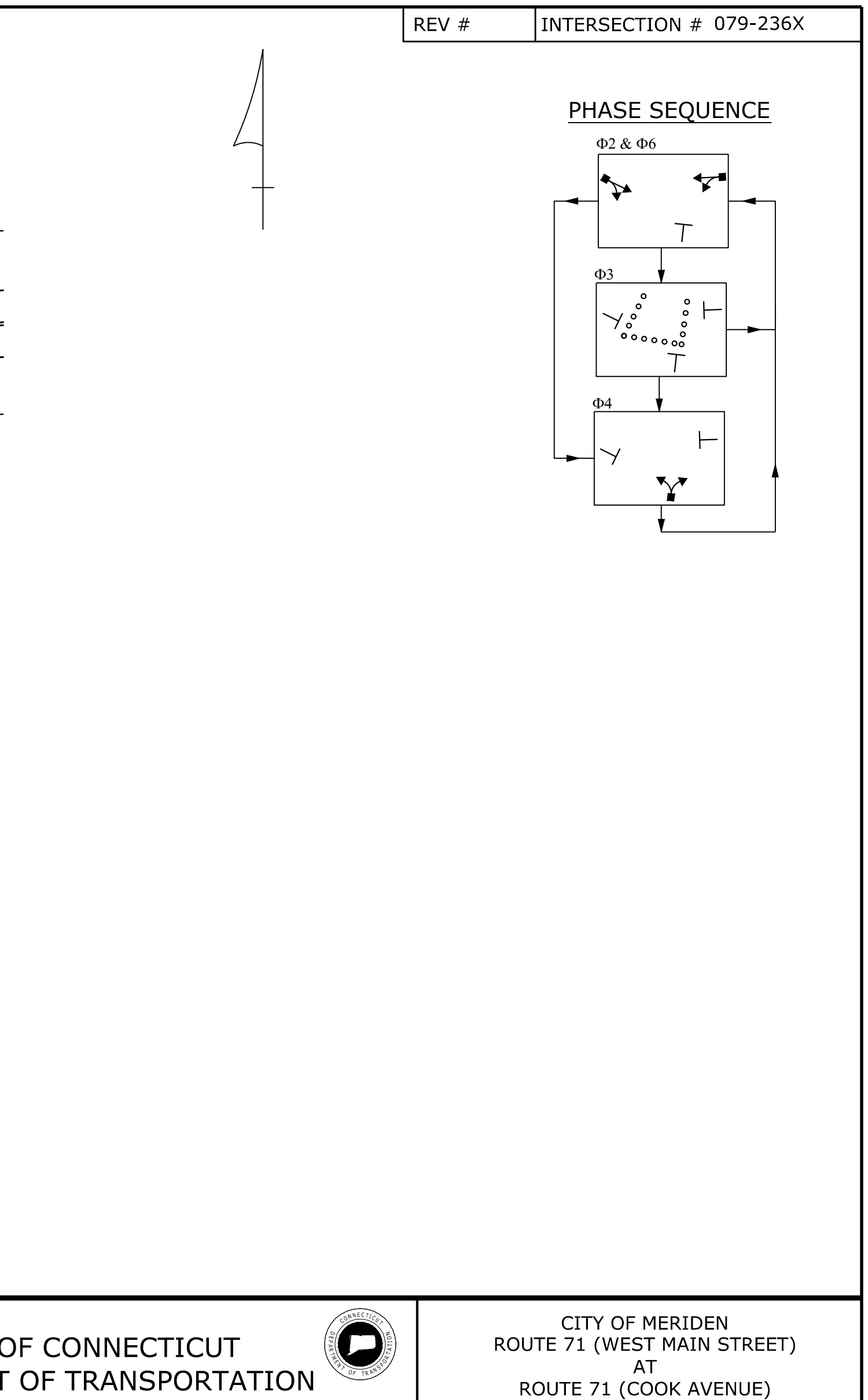
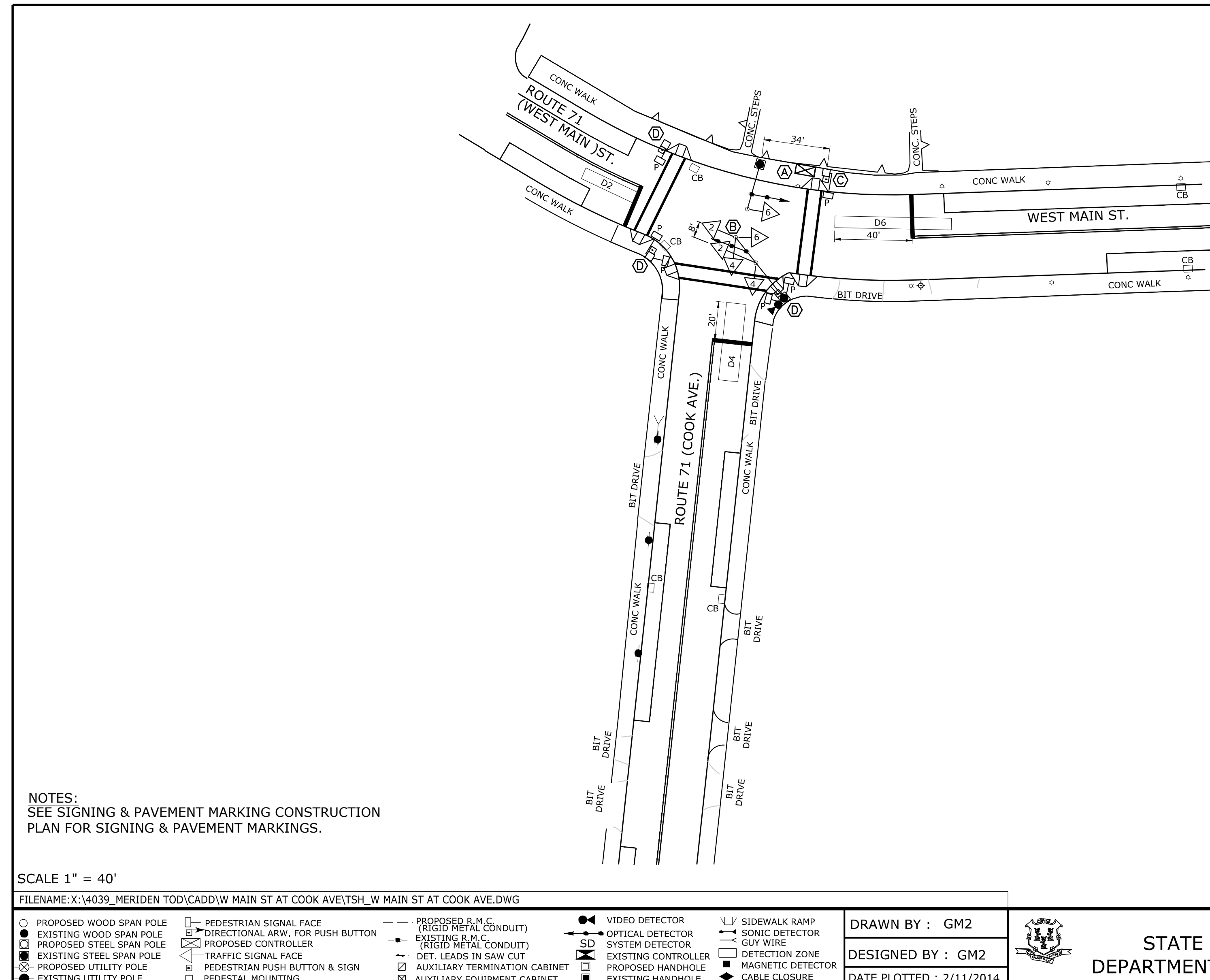

NO.	DATE	INIT.	DESCRIPTION

TOWN: MERIDEN  
DRAWING TITLE: TRAFFIC CONTROL SIGNAL PLAN  
PROJECT NO.: XXX-XXXX  
DRAWING NO.: TCS-08  
SHEET NO.: 37

**END WEST MAIN ST. STA. 124+63.00  
 BEGIN EAST MAIN ST. STA. 124+63.00  
 SEE WEST MAIN ST. PLAN AND  
 PROFILE SHEET FOR CONTINUITY.**

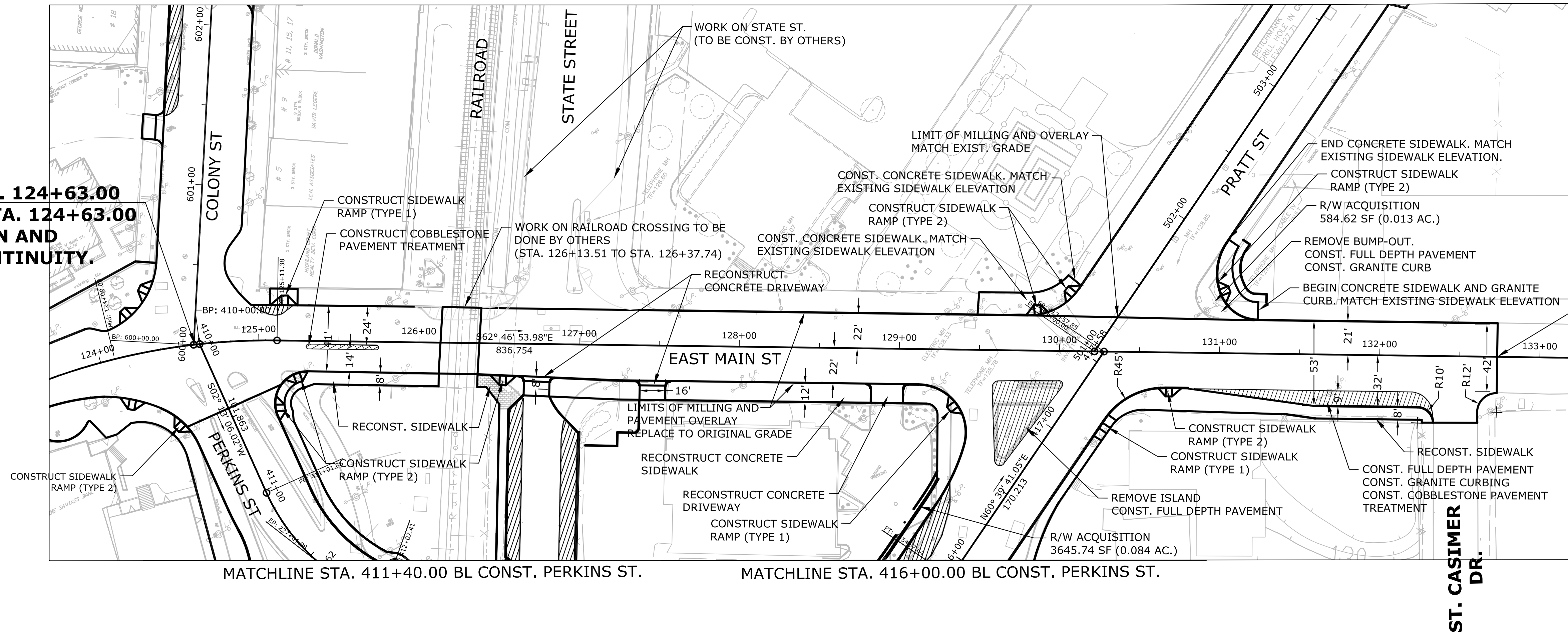

**END MILLING AND OVERLAY  
 STA. 132+73.50**

MATCHLINE STA. 411+40.00 BL CONST. PERKINS ST.

MATCHLINE STA. 416+00.00 BL CONST. PERKINS ST.

**ST. CASIMER  
 DR.**

**EAST MAIN ST.**

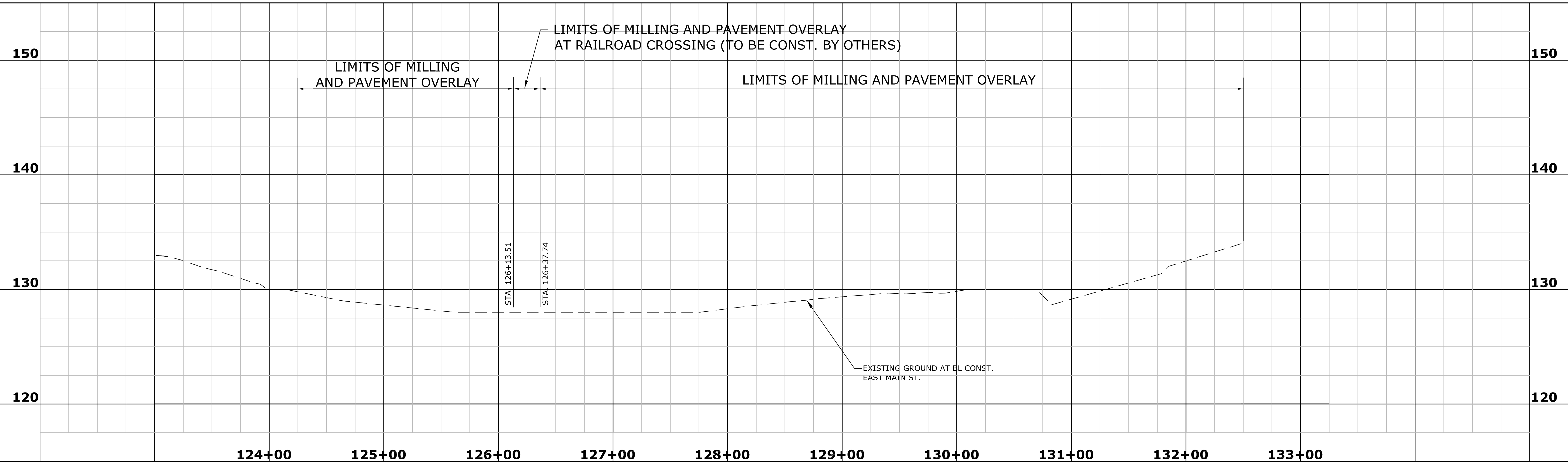

REV.	DATE	DESCRIPTION REVISIONS	SHEET. NO.	HORIZONTAL SCALE (1" = 40') 	DESIGNER: QLE DRAFTER: LV CHECKED BY: SK DATE CHECKED:		900 Chapel Street, Suite 1400 New Haven, Connecticut 06510 Phone: 203-865-2191 Fax: 203-624-0484 www.cdmsmith.com	ENGINEER:  APPROVED BY:	DATE:	PROJECT TITLE: <b>TRAFFIC IMPROVEMENTS FOR          TRANSIT ORIENTED          DEVELOPMENT DISTRICT</b>	TOWN: <b>MERIDEN</b>	PROJECT NO.: 0000-0000	
				VERTICAL SCALE (1" = 10') 						CADD	PLOTTED -	DRAWING TITLE: <b>ROADWAY PLAN AND          PROFILE (6)</b>	DRAWING NO.: <b>PLN-06</b>
												SHEET NO.: <b>15</b>	

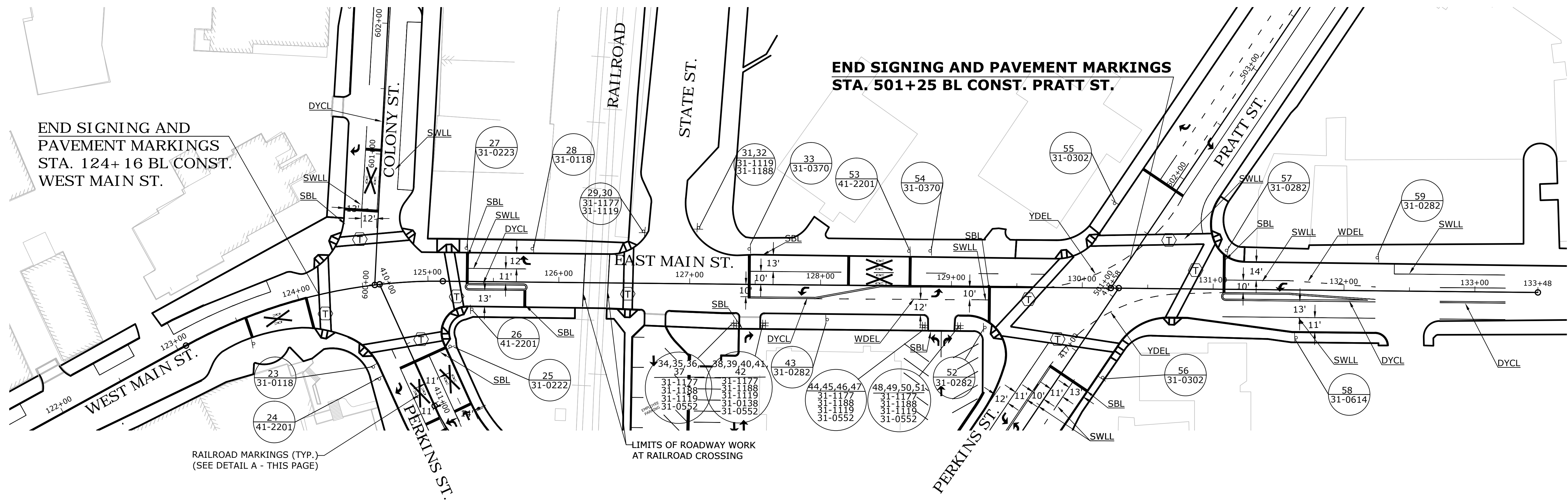

EAST MAIN ST.

**PAVEMENT MARKING LEGEND**

- BWLL - 4in BROKEN WHITE LANE LINE
- DYCL - 4in DOUBLE YELLOW CENTER LINE
- SBL - 12in STOP BAR LINE (WHITE)
- SWLL - 4in SOLID WHITE LANE LINE
- SYL - 4in SOLID YELLOW LINE
- WDEL - 4in WHITE DOTTED EXTENSION LINE

**NOTES:**  
 (T) BAR TYPE CROSSWALK  
 TOWN MAINTAINED

**NOTES:**  
 RAILROAD GRADE CROSSINGS  
 1. RAILROAD MARKINGS SHALL BE WHITE.  
 2. ON MULTI-LANE ROADS THE TRANSVERSE BANDS SHOULD EXTEND ACROSS THE APPROACH LANES AND INDIVIDUAL R X R SYMBOLS SHOULD BE USED IN EACH APPROACH LANE.

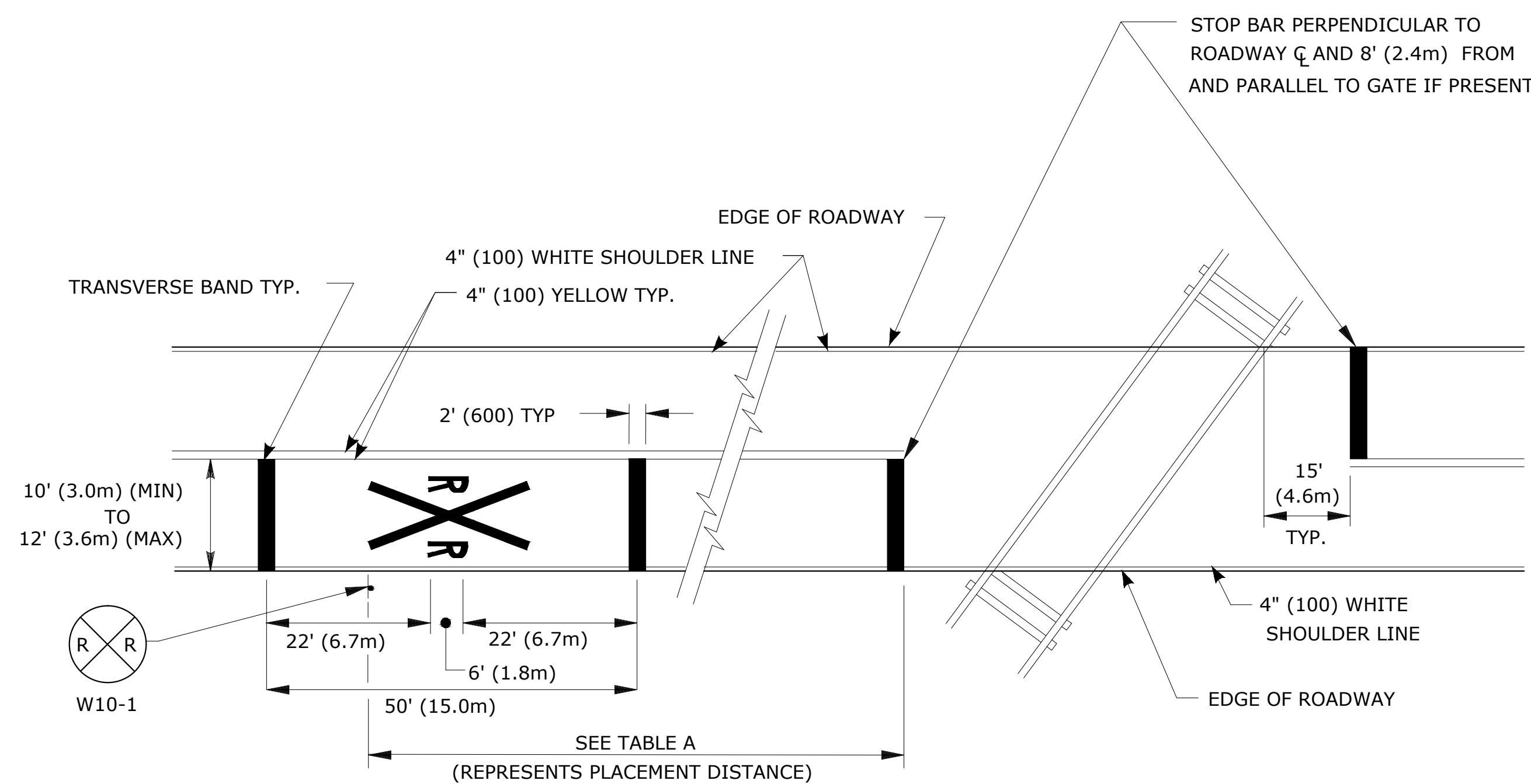

**PAVEMENT MARKINGS FOR RAILROAD GRADE CROSSINGS**

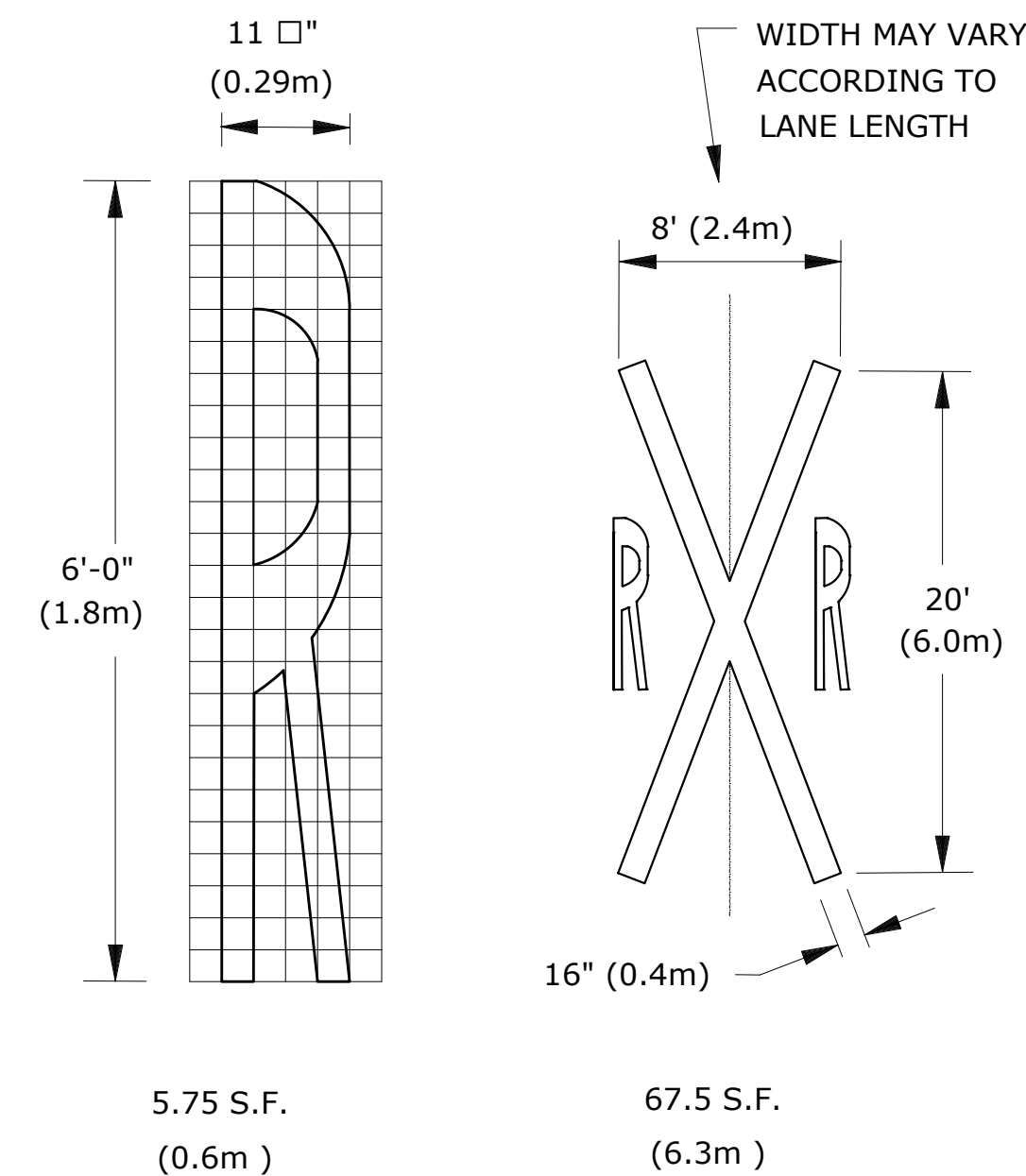

TABLE A	
POSTED OR 85 PERCENTILE SPEED M.P.H.	DISTANCE FT. (m)
20	
25	
30	100 (30)
35	150 (46)
40	225 (69)
45	300 (91)
50	375 (114)
55	450 (137)
60	550 (168)
65	650 (198)

NO SUGGESTED MINIMUM DISTANCE, AT THESE SPEEDS, SIGN LOCATION DEPENDS ON PHYSICAL CONDITIONS AT SITE, HOWEVER SHOULD NOT BE LESS THAN 50' (15m).

REV.	DATE	DESCRIPTION REVISIONS	SHEET. NO.

DESIGNER: SK  
 DRAFTER: LV  
 CHECKED BY: SK  
 DATE CHECKED:



900 Chapel Street, Suite 1400  
 New Haven, Connecticut 06510  
 Phone: 203-865-2191  
 Fax: 203-624-0484  
 www.cdmsmith.com

ENGINEER:  
 APPROVED BY: DATE:

PROJECT TITLE:  
**TRAFFIC IMPROVEMENTS FOR TRANSIT ORIENTED DEVELOPMENT DISTRICT**  
 CADD

TOWN: **MERIDEN**  
 DRAWING TITLE:  
**SIGNING AND PAVEMENT MARKING PLANS**

PROJECT NO.: 131061-95916  
 DRAWING NO.: **SPM-04**  
 SHEET NO.: **25**



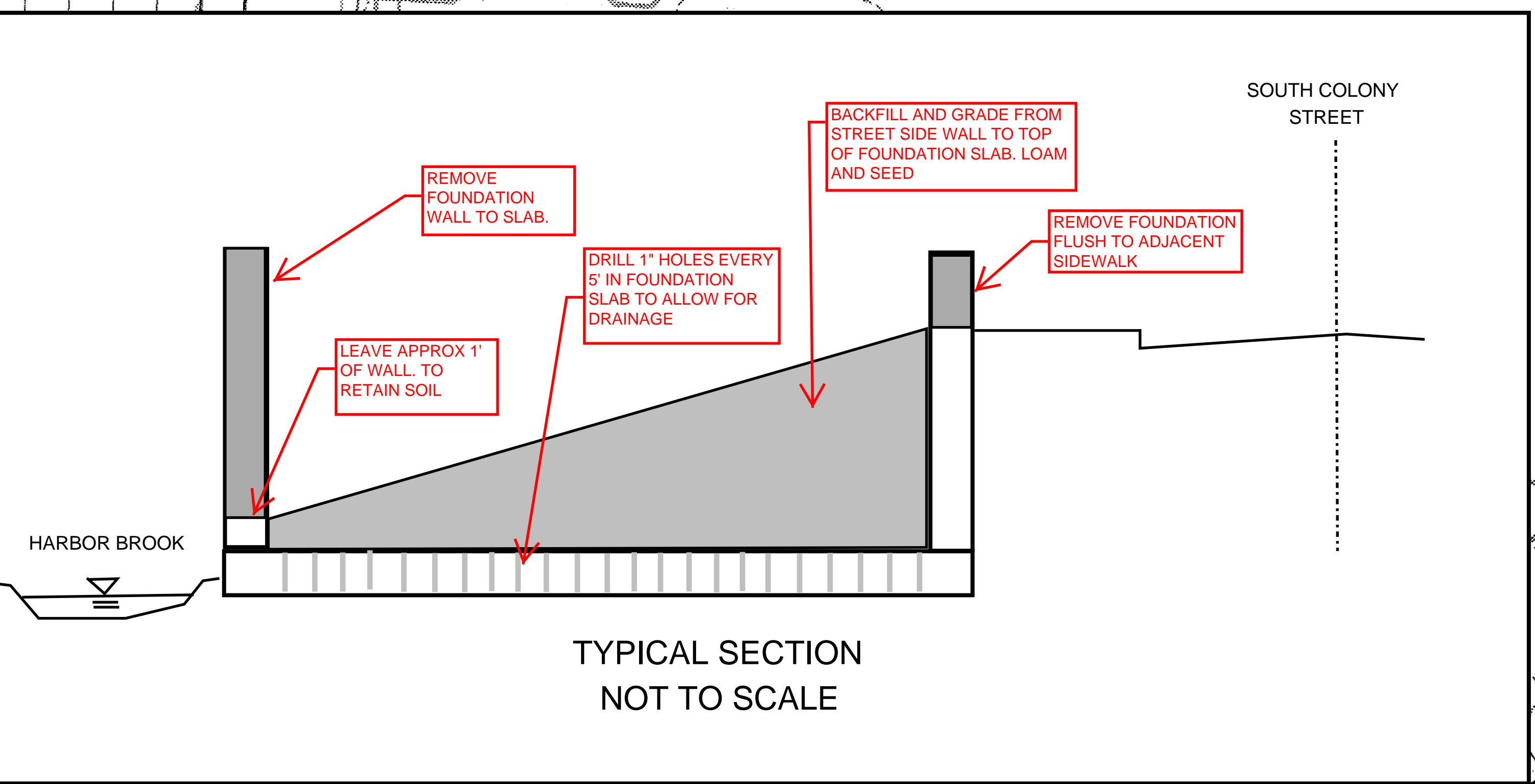

TYPICAL SECTION  
NOT TO SCALE

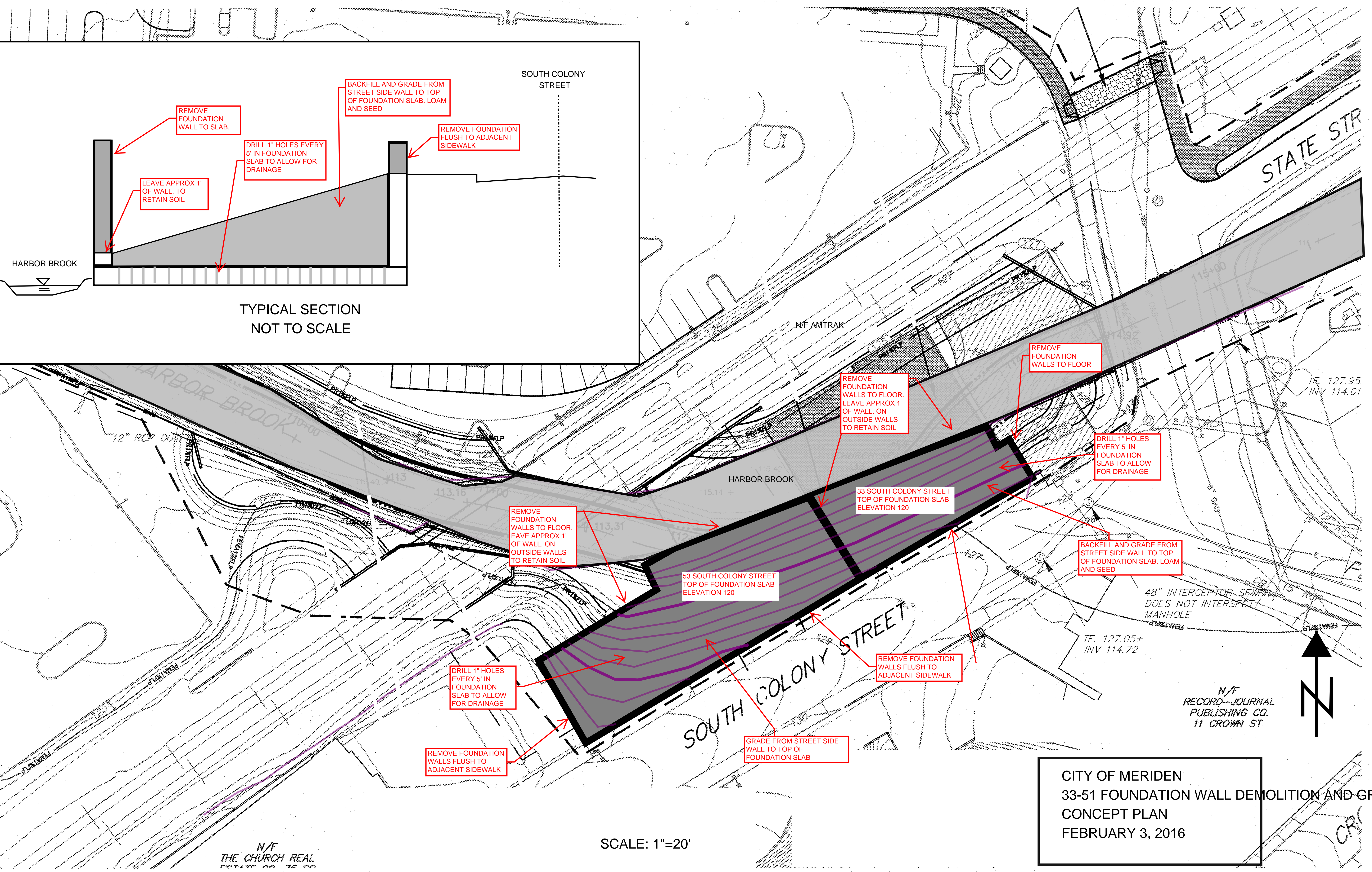

SCALE: 1"=20'

CITY OF MERIDEN  
33-51 FOUNDATION WALL DEMOLITION AND GRADING  
CONCEPT PLAN  
FEBRUARY 3, 2016

N/F  
RECORD-JOURNAL  
PUBLISHING CO.  
11 CROWN ST.

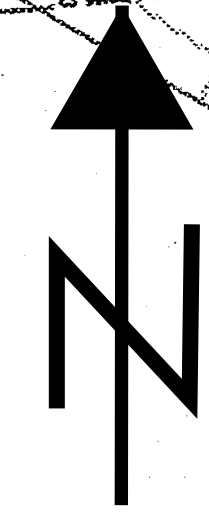

N/F  
THE CHURCH REAL  
ESTATE CO. 75 CO

Item # 9  
DATE:  
2/1/16

RESOLUTION

Presented by:

David Lowell, by Request

WHEREAS, the State of Connecticut Office of Policy and Management has solicited applications for grant funds to assist municipalities with transit oriented development (TOD) activities, and

WHEREAS, the City is engaged in various TOD activities that are eligible for funding under the grant, and

WHEREAS, it is in the City's interest to implement the TOD Multimodal Roadway Improvement Plan in the TOD Zoning District including the construction of roadway, pedestrian, and bicycle improvements along West Main Street, Colony Street, and State Street, which are key connectors into downtown Meriden and to the new Transit Center.

Now, Therefore Be It Resolved that the City Council authorizes the submission of a \$2 million grant application to implement the Multi-Modal Roadway Improvement Plan in the TOD Zoning District in accordance with the Responsible Growth and Transit-Oriented Development (TOD) Grant Request for Applications;

Now, Therefore Be It Resolved that the City Council authorizes the City Manager Lawrence J. Kendzior, or his successor(s), to sign the grant application and to sign any other documents associated with administering the grant, if awarded, including any amendments thereto. Such grant application is attached to and made a part of this record.

Certified a true copy of a Resolution approved by the Meriden City Council at their meeting on February 1, 2016 which has not been rescinded or modified in any way whatsoever.

Certified this 4th day of February 2016

Denise L. Grandy  
Denise L. Grandy - City Clerk

Agenda date:	2/1/2016
Action taken:	Adopted
Mayer's signature:	
Legal notice:	
Public hearing:	
Acknowledgment:	
Referred to:	
Copies sent to:	
Lori N. Canney Clerk of the Council	